

Smart Electromotor Controller

FESTO

Description

Commissioning
Type SEC-AC-305
Type SEC-AC-508



Description

192 347
en 0007NH



Contents and general instructions

Original	de
Translation	Festo AG & Co., Abtl. KI-TD
Layout	Festo AG & Co., Abtl. KG-GD
Type setting	DUCOM
Edition	en 0007NH
Title	MANUAL-EN
Designation	P.BE-SEC-AC-SW-EN
Order no.	192 347

© (Festo AG & Co., D-73726 Esslingen, Federal Republic of Germany 2000)

Internet: <http://www.festo.com>

E-Mail: service_international@festo.com

The copying, distribution and utilization of this document as well as the communication of its contents to others without expressed authorization is prohibited. Offenders will be held liable for the payment of damages. All rights reserved, in particular the right to carry out patent, utility model or ornamental design registration.

Contents and general instructions

Designated use	VIII
Target group	IX
The aim of this manual	IX
Trade marks	X
Service	X
Important user instructions	XI
1. Before commissioning	1-1
1.1 Installation and fitting	1-3
1.2 Check readiness to operate	1-4
2. The parametrizing program	2-1
2.1 Scope of deliverx	2-3
2.2 What can the parametrizing program do?	2-3
2.3 Hardware and software requirements	2-4
2.4 Using the parametrizing program	2-5
2.4.1 Standard available buttons	2-5
2.4.2 Fields for numerical entries	2-6
2.4.3 Window positions	2-7
3. Installation, first program start and communication	3-1
3.1 Installation	3-3
3.2 First program start	3-4
3.3 Setting communication	3-5
3.4 Setting the serial interface	3-7
3.5 Solving problems with serial communication	3-9

4.	Basic settings	4-1
4.1	Setting the mode of the parametrizing program	4-3
4.2	Loading preset parameter blocks	4-5
4.3	Setting the current limit values	4-9
4.4	Setting the controller enable logic	4-11
4.5	Setting the offset angle, phase sequence and number of pole pairs	4-12
4.6	Setting the current regulator	4-14
4.7	Pre-setting the speed regulator	4-16
4.7.1	Determining the limit switch logic	4-17
4.8	Selecting the operating mode	4-18
4.8.1	Summary	4-18
4.8.2	Torque control/speed control	4-19
4.8.3	Additional options	4-19
4.9	Nominal value selectors	4-20
4.10	Configuring the actual value display	4-21
5.	First start and optimizing the motor	5-1
5.1	Testing the controller enable	5-3
5.2	Setting the actual speed value filter	5-6
5.3	Optimizing the speed regulator	5-7
5.3.1	Summary	5-7
5.3.2	Carrying out the optimization	5-8
5.3.3	Strategies for optimizing	5-12
5.3.4	Further optimizations	5-15
5.4	Optimizing the positioning module	5-16
5.4.1	Setting the positioning module	5-16
5.4.2	Carrying out optimization	5-18
6.	Working with parameter blocks	6-1
6.1	General information	6-3
6.2	Loading and saving parameter blocks	6-5
6.3	Offline parametrizing	6-6

7.	Informations on the automatic identification	7-1
7.1	Information on the offset angle, phase sequence and number of pole pairs	7-3
7.1.1	Summary	7-3
7.1.2	Automatic identification	7-4
7.2	Information on the current regulator	7-5
8.	Standard applications and settings of the parametrizing program	8-1
8.1	Layout of the controller	8-3
8.2	Torque-control mode	8-4
8.3	Speed-control mode	8-6
8.4	Positioning	8-8
8.4.1	Reference travel	8-9
8.4.2	Setting positions	8-14
8.4.3	Setting digital outputs	8-20
8.5	Master-slave operation	8-21
8.5.1	Speed-synchronous positioning	8-22
8.5.2	Position-synchronous movement	8-26
8.6	Timing the digital signals	8-29
8.6.1	Digital inputs	8-29
8.6.2	Timing the final stage enable and controller enable	8-30
8.6.3	Timing the limit switches	8-32
8.6.4	Timing the control signals for the positioning module	8-33
8.6.5	Feedback messages from the servo controller	8-37

9.	Extended functions of the parametrizing program	9-1
9.1	File/Transfer window	9-3
9.2	File/Installation device files	9-4
9.3	File/Concluding the program	9-4
9.4	Nominal values/Nominal value specification	9-5
9.5	Analogue monitor	9-7
9.6	Parameters/Device parameters/Nominal value scaling	9-8
9.7	Parameters/Device parameters/Nominal value integrator ramp	9-9
9.8	Parameters/Device parameters/Speed message	9-12
9.9	Parameters/Device parameters/Digital outputs	9-13
9.10	Parameters/Device parameters/Intermediate circuit voltage	9-14
9.11	Parameters/Device parameters/Automatic brake	9-15
9.12	Error window	9-17
9.13	Options/German - English	9-19
9.14	Options/User mode	9-19
9.15	Options/Window for RS232 transmission	9-20
9.16	Options/Torque in Nm	9-21
9.17	Options/Oscilloscope	9-21
9.17.1	Register card "Channel representation"	9-22
9.17.2	Register card "Trigger"	9-23
9.17.3	Register card "Generator"	9-26
9.17.4	Register card "Controller"	9-27
9.17.5	Lower status bar	9-28
9.18	Help/Using help	9-30
9.19	Help/Themes	9-30
9.20	Helps/Information	9-31
9.21	Fast access via the icon bar	9-32

10.	Diagnosis and error treatment	10-1
10.1	Status display	10-3
10.2	General information	10-3
10.3	Outputting faults	10-4
10.4	Error list	10-5
10.5	Warning: old firmware	10-7
11.	List of the RS232 commands	11-1
11.1	RS232 test possibilities	11-3
11.2	General commands/messages	11-5
11.3	Selecting the operating mode	11-6
11.4	Specifying the speed	11-6
11.5	Reference travel/Position control	11-7
11.6	Synchronization unit	11-10
11.7	Parking brake	11-10
11.8	Commissioning/Calibrating	11-11
11.9	Parameter commands	11-11
11.10	Example of parametrizing	11-12
A.	Technical Appendix	A-1

Designated use

The SEC-AC (Smart Electromotor Controller) has been designed for use in control cabinets for supplying AC servo motors and for controlling their torque (current), speed and position.

The SEC-AC must be operated in a safe working environment. An EMERGENCY STOP circuit must be installed for the system.

Operate the SEC-AC only under the permitted ambient conditions.

The SEC-AC may only be used in stationary industrial and commercial use. The electromagnetic interference immunity of the power electronics is not designed for operation in mobile systems, in households or firms connected directly to the low voltage network.

Fit the SEC-AC with screening into an earthed control cabinet. Otherwise, the electromagnetic compatibility (EMC) of the power electronics will not be guaranteed. Use the SEC-AC only as follows:

- as designated
- in a technically faultless state
- without undertaking any modifications.

If used in conjunction with additional commercially-available components, such as sensors and actuators, the specified maximum limits (temperatures, electrical datas, torques, etc.) must be observed.

Please comply with national and local safety laws and regulations.

Target group

This manual is aimed at technicians trained in control and automation technology, fitters etc. who

- are working for the first time with digital drive controllers
- are already familiar with digital drive controllers, but who are installing a digital drive controller like the SEC-AC for the first time.

The aim of this manual

This manual will help you to carry out the first commissioning of the SEC-AC successfully.

In this manual you will find important information and acquire the basic knowledge necessary for operating the SEC-AC correctly.

Most work steps in this manual are divided into two parts:

- Description part: here you will learn important instructions and the aim of each individual work step.
- Instruction part: here you carry out the work step.

In the left-hand margin you will find symbols which simplify the orientation in this manual for you during commissioning.

Trade marks

All product names in this document may be registered trade marks. All trade marks in this document are only used for identifying the individual product.

Service

If you have any technical problems, please contact your local Festo Service.

Important user instructions

Danger categories

This manual contains instructions on the dangers which may occur if the product is not used correctly. These instructions are marked with a heading (Warning, Caution, etc.), printed on a shaded background and accompanied by a pictogram. A distinction is made between the following danger categories:



Warning

This means that there is a danger of serious human injury and damage to property if these instructions are not observed.



Caution

This means that there is a danger of human injury and damage to property if these instructions are not observed.



Please note

This means that there is a danger of damage to property if these instructions are not observed.

In addition, the following pictogram marks passages in the text which describe activities involving electrostatically sensitive components:



Electrostatically sensitive components: Incorrect handling may result in damage to the components.

Safety instructions



Warning

Inside the SEC-AC and on its connections there are high voltages which can be extremely dangerous.

Switch off the power supply of the SEC-AC, therefore, and wait for at least 5 minutes in order that the intermediate circuit can discharge before you connect or disconnect any plugs.



Warning

During installation, commissioning and maintenance you must observe the safety and accident prevention regulations valid for the specific application.

The following regulations apply but are not guaranteed to be complete:

- VDE 0100 Regulations for setting up high-voltage systems up to 1000 V
- VDE 0113 Electrical equipment in machines
- VDE 0160 Equipment in high-voltage systems with electronic operating methods

Marking special information

The following pictograms mark passages in the text containing special information.

Pictograms



Information:
recommendations, tips and references to other sources of information.



Accessories:
information on necessary or useful accessories for the Festo product.



Environment:
information on the environmentally-friendly use of Festo products.

Text markings

- The bullet denotes activities which can be carried out in any sequence.
- 1. Figures denote activities which must be carried out in the order specified.
- Hyphens denote general activities.

Conventions

Various parts of the program are identified in this manual by the way in which they are written.

Menu entries

Menu entries are framed by square brackets, e.g. menu [File].

Names of windows

Names of windows, dialogue windows and buttons, e.g. "Cancel" as well as designations, e.g. "DGPL-PPV-A-KF-B" are represented in inverted commas.

Examples of programs

Examples of programs are represented in a different type, e.g. "N0010 G00 X250".

Keys

The names of keys on the PC keyboard are represented in the text with upper-case letters, e.g. ENTER key, CTRL, C, F1, etc.

Certain functions require two keys to be pressed simultaneously. Hold e.g. the CTRL key pressed down and press the C-key at the same time. This is shown in the text as CTRL+C.

The left mouse button is always meant if the manual refers to "clicking" or "double-clicking". If the right-hand mouse button is to be used, this will be mentioned in the text.

References to other chapter sections as well as "figurative terms" are in simple inverted commas.

Before commissioning

Chapter 1

1. Before commissioning

1.	Vor der Inbetriebnahme	1-1
1.1	Installation and fitting	1-3
1.2	Check readiness to operate	1-4

1. Before commissioning

1.1 Installation and fitting

Make sure that the drive is installed and fitted correctly.
Check that:

- the drive is mounted firmly on its base and is free of distortion;
- the working space in which the axis and the work load move is sufficient for operation with the work load;
- the work load does not collide with the motor or the axis gears when the slide moves into the end position.



Warning

Danger of electric shock!

- Make sure that the complete system is disconnected from the mains power supply before carrying out work on the power supply circuit or the system. Use the main switch to disconnect the system from the power supply.

Make sure that all the cables from the power supply to the drive are laid and connected correctly. Make sure also that:

- the cables for the power supply, for controlling the motor and for transmitting signals do not lie on top of each other, as reciprocal electromagnetic effects may impair the functioning;
- the motor cables are connected correctly to the relevant power electronics;
- that the actuators are disconnected for the first commissioning and that the motor is disconnected from the drive shaft.

1. Before commissioning

1.2 Check readiness to operate

1. Make sure that the Controller enable switch is switched off.
2. Switch on the AC/DC voltage supply for the device. The green LED on the front of the SEC-AC should now light up.



Caution

If the green LED does not light up, switch off the power supply immediately. There is a fault.

If the 7-segment display shows a number comprising two figures, it is an error message, the cause of which you must rectify. In this case, read further in the section "Diagnosis and error treatment." If no display lights up on the SEC-AC, you should carry out the following steps:

1. Switch off the power supply.
2. Wait for five minutes to enable the intermediate circuit to discharge.
3. Check all connecting cables.
4. Check that the 24 V power supply functions correctly.
5. Switch on the power supply again.

1. Before commissioning

If the cause of the fault can be rectified, the error must be quitted (menu [Error], [Delete]).

You can do this by pressing the Reset button or software-controlled via the parametrizing program.



Warning

If faults occur during commissioning, high acceleration forces may cause considerable damage. Commission the motor the first time, therefore, without a load connected, e.g. with free-running motor shaft, in order to keep the acceleration forces as low as possible.

1. Before commissioning

The parametrizing program

Chapter 2

2. The parametrizing program

2.	The parametrizing program	2-1
2.1	Scope of delivery	2-3
2.2	What can the parametrizing program do?	2-3
2.3	Hardware and software requirements	2-4
2.4	Using the parametrizing program	2-5
2.4.1	Standard available buttons	2-5
2.4.2	Fields for numerical entries	2-6
2.4.3	Window positions	2-7

2. The parametrizing program

2.1 Scope of delivery

CD ROM with:

- programming software Wmemoc
- device files
- parametrizing files
- description of the SEC-AC in electronic form

2.2 What can the parametrizing program do?

With the parametrizing program you can adapt the SEC-AC to optimally suit your application.

The parametrizing program offers the following features:

- All parameters can be set via the PC
- It can be used with Windows
- Automatic recognition of the controller connected
- Parameter sets are recorded on an external data storage device
- New firmware versions can be loaded
- Menus and helps in either German or English
- Online helps
- Oscilloscope function
- The use (download) of pre-optimized parameters for complete Festo positioning axes.

2. The parametrizing program

2.3 Hardware and software requirements

The requirements for installing the parametrizing program are:

IBM-compatible PC-AT, as from 80486 processor with at least 16 MB main memory and at least 3 MB free hard disc memory

- Windows 95, 98 or NT
- CD ROM drive
- an unused serial interface

2. The parametrizing program

2.4 Using the parametrizing program

2.4.1 Standard available buttons

If you open a window while working with the parametrizing program, you will find the following buttons at the top right in this window:

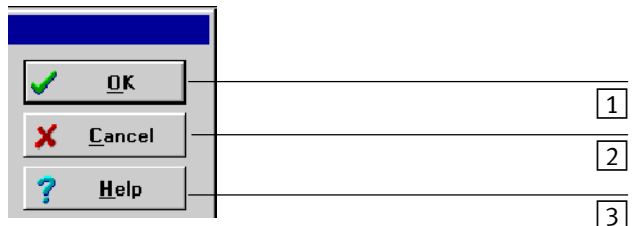

- 1** OK All the modifications made will be accepted and transmitted to the SEC-AC. The window will be closed.
- 2** Abort All the modifications made will be cancelled, even values already transmitted will be restored. The window will be closed.
- 3** Help This opens a help menu which gives you explanations of the currently opened window.

Fig. 2/1

You can actuate one of these buttons by clicking it with the left-hand mouse key. If the buttons differ in some menus from that described here, please refer to your manual or online help for more detailed information.

2. The parametrizing program

2.4.2 Fields for numerical entries

In the windows of the parametrizing program you will always find fields for numerical entries as shown below.

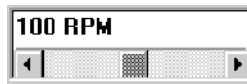

Fig. 2/2

Entries can be made in the following ways:

1. Directly on the keyboard. Enter the value directly in the entry line. As long as the entry is not yet complete, the text will be shown in thin print and will not yet be transferred to the parametrizing program (see diagram below). To conclude the entry press the ENTER key or switch to another entry field. The numerical value will then be shown in heavy print.



Fig. 2/3

2. Clicking the arrow keys. The value changes in small steps (accurate adjustment).
3. Clicking the surfaces between the grey box and the arrow keys. The value changes in large steps (rough adjustment).
4. Clicking the grey box and moving the mouse with the left-hand key pressed down. The value can easily be preset in the complete value range.

2. The parametrizing program

2.4.3 Window positions

In the basic setting, the command window (top left), the status window (top centre) and the actual value window (top right) are always open. You can reduce these windows to icons (these windows cannot be closed) and open or close others, as in WINDOWS (See figure in the chapter 'Setting communication').

2. The parametrizing program

Installation, first program start and communication

Chapter 3

3. Installation, first program start and communication

3.	Installation, first program start and communication	3-1
3.1	Installation	3-3
3.2	First program start	3-4
3.3	Setting communication	3-5
3.4	Setting the serial interface	3-7
3.5	Solving problems with serial communication	3-9

3. Installation, first program start and communication

3.1 Installation



Please note

The parametrizing program consists of two parts: the program part and the device data. Only the installation of the program part is described in the chapter 'Installation'. Before installing the complete parametrizing program, you must work through the chapter '**First program start**'.

The parametrizing program for the SEC-AC must be installed on your hard disc. The installation program "SETUP.EXE" will do this task for you. In order to install the parametrizing program, proceed as follows:

1. Make sure that the diskettes with the parametrizing program are write-protected. The hole underneath the small plastic slide in the diskette must still be visible.
2. Place the data storage device in the drive.
3. Start the WINDOWS Explorer.
4. Switch to the drive containing the data storage device with the parametrizing program.
5. Start the program "SETUP.EXE" (double click).

The installation program now creates a new program group for you with the name "WMEMOC." It automatically copies all the necessary files onto your hard disc and requests you to change the diskette. If installation has been successful, this will be displayed in an appropriate window.

6. The parametrizing program is now ready for the first program start. Please read further in the chapter 'First program start'.

3. Installation, first program start and communication

3.2 First program start

Before the program can become fully functional, the device files must be installed. This is carried out during the first program start. Proceed as follows.

- Start the parametrizing program by double-clicking the appropriate symbol ([Start]/[Programs]/[Parametrizing program]). The following window will appear:

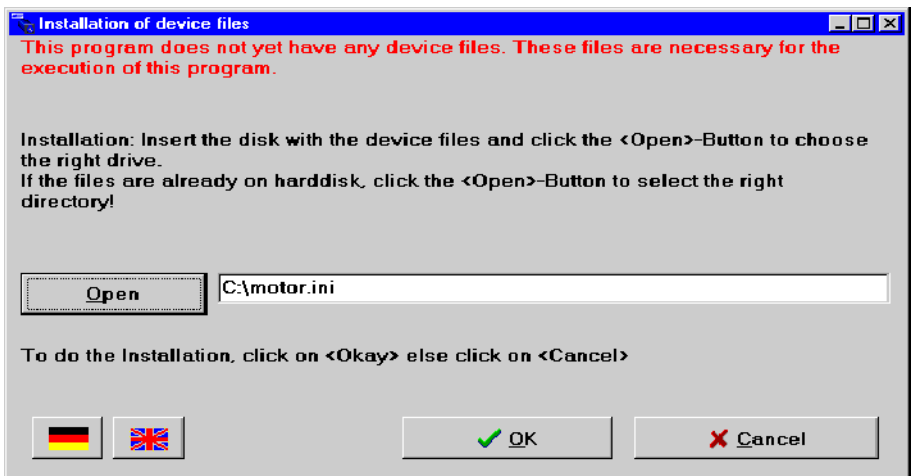

Fig. 3/1

Open

- Insert the data storage device with the device data and click the Open button. Select the drive and click on “OK”. Then click the “OK” button in the window shown above.
- Conclude the program. The parametrizing program is now completely installed.

3. Installation, first program start and communication

3.3 Setting communication

Serial interface

The parametrizing program communicates with the servo controller via the serial interface. In order to do this, it needs to know which serial interface (COM port number) is being used.

When supplied from the factory, the parametrizing program is set as follows:

- interface COM1
- baud rate 9600 Baud (factory setting of servo controller)

When it is started, the program tries to communicate with a servo controller. If this fails, an error message will be shown.

Before the data for communication can be set correctly, you must carry out the following steps:

1. Connect the servo controller completely.
2. Connect an unused COM interface on the PC to the servo by means of a zero modem cable.
3. Switch on the servo controller.
4. Start the parametrizing program.

3. Installation, first program start and communication

If the parametrizing interface has a green online button (see diagrams below), the communication parameters are already set correctly and no modifications need to be made.



If, however, you find an error message, please read further in the chapters 'Setting the serial interface' and/or 'Solving problems with serial communication'.

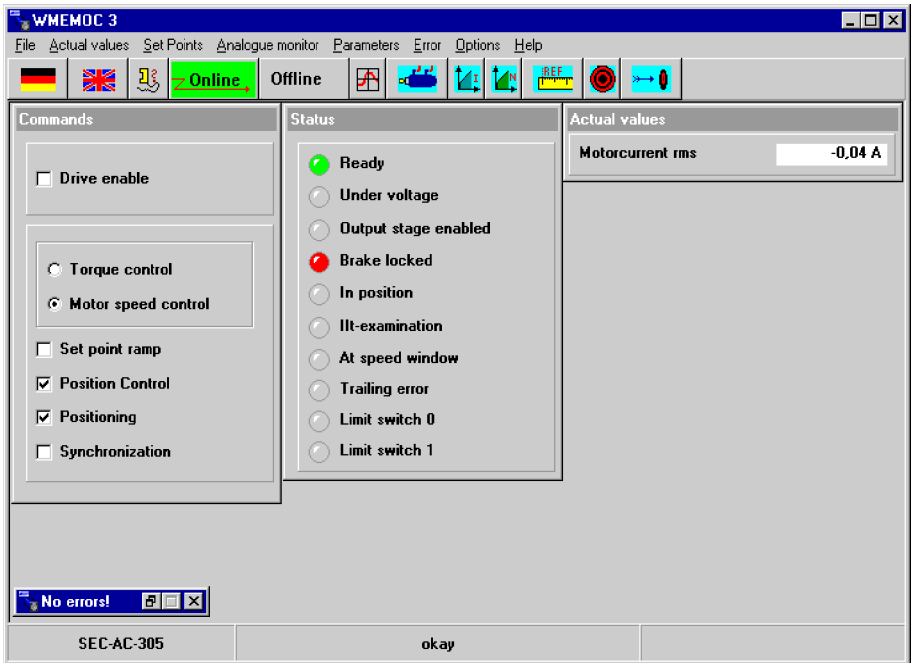

Fig. 3/2

3. Installation, first program start and communication

3.4 Setting the serial interface

If the parametrizing program cannot open the serial interface, the following error window will be shown when the program starts:

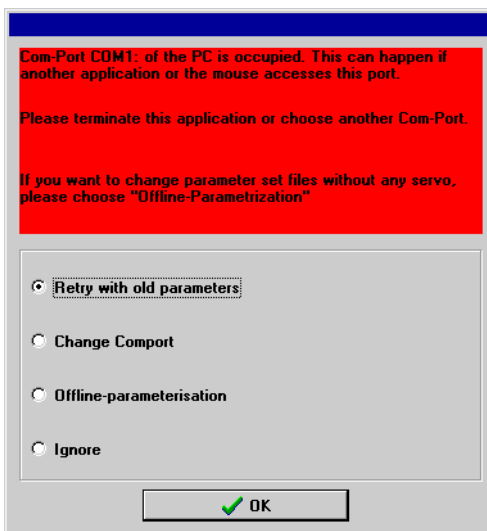

Fig. 3/3

3. Installation, first program start and communication

Incorrectly set interface	This fault can be caused either by an incorrectly set interface (usually the mouse driver) or by another Windows or DOS program which has access to the serial interface.
Change comport	<p>In order to correct an incorrectly set interface, click the menu item "Change comport" and follow the instructions given there.</p> <p>In order to solve the problem of conflict with a program which has access to the interface, conclude the other program (in the case of DOS programs, you must conclude the DOS shell as well) and then click "Retry with old parameters".</p>
Offline parametrizing	"Offline parametrization" is not intended for the first commissioning. It serves simply as a preparation for desk work (see chapter 'Offline programming').
Ignore	If you click "Ignore", the program will become inactive and will not try to make contact with the servo or offline parametrizing. The fault will not be rectified.

3. Installation, first program start and communication

3.5 Solving problems with serial communication

If the parametrizing program cannot establish a connection with the servo controller, the following error window will be shown:

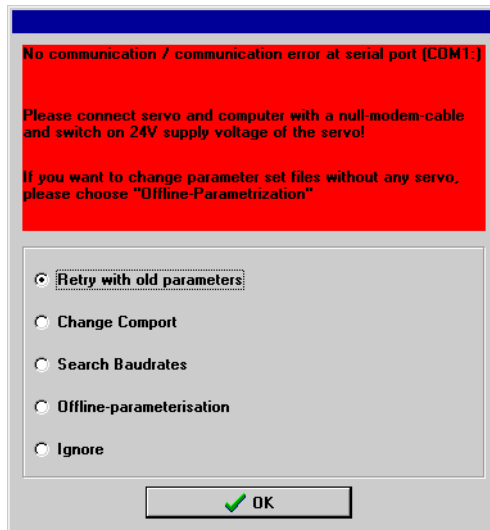

Fig. 3/4

3. Installation, first program start and communication

The table below lists the possible causes of faults and how to rectify them.

Cause	Remedy
Connection cannot be made	Click “Retry with old parameters”
The selected Comport is not correct	Click “Change comport” and follow the instructions there
Baud rates of parametrizing program and of servo are not the same	Click “Search for baudrates”
Communication interrupted from servo side	Carry out reset on servo , then click “Retry with old parameters”
Hardware faults: <ul style="list-style-type: none">– Servo not switched on– Connecting cable not plugged in– Connecting cable broken– Incorrect connecting cable	Rectify faults, then click “Retry with old parameters. See manual ‘Installation and fitting’, e.g. “RS232 cable”

Fig. 3/5 Causes of faults and how to rectify them

Basic settings

Chapter 4

4. Basic settings

4.	Basic settings	4-1
4.1	Setting the mode of the parametrizing program	4-3
4.2	Loading preset parameter sets	4-5
4.3	Setting the current limit values	4-9
4.4	Setting the regulator enable logic	4-11
4.5	Setting the offset angle, phase sequence and number of pole pairs	4-12
4.6	Setting the current controller	4-14
4.7	Pre-setting the speed controller	4-16
4.7.1	Determining the limit switch logic	4-17
4.8	Selecting the operating mode	4-18
4.8.1	Summary	4-18
4.8.2	Torque control/speed control	4-19
4.8.3	Additional options	4-19
4.9	Setpoint-selectors	4-20
4.10	Configuring the actual value display	4-21

4. Basic settings

The basic settings of the parametrizing program and of the controller can be undertaken when:

- the program has been installed correctly, and when
- communication with the servo controller has been established.



Caution

Carry out the steps for the basic settings in the sequence stated in the manual. If this sequence is not observed, the motor and/or the servo controller may be damaged.

4.1 Setting the mode of the parametrizing program

In order to be able to work optimally with the parametrizing program, various user modes are offered in which only certain functions can be accessed. The following modes can be set:

- “Beginner”
All the parameters can be set, except positioning module, positioning and synchronizing (available via fast-access buttons)
- “Advanced”
All user-relevant parameters can be set
- “Expert”
Access to controller-internal parameters which cannot be modified by the user without knowledge of the device and its applications

4. Basic settings

Select the mode “Beginner“ in order to carry out the first commissioning. Select the mode “Expert“ for optimizing the system and for parametrizing the positioning module.

Proceed as follows:

1. Select menu item [Options]/[User mode].

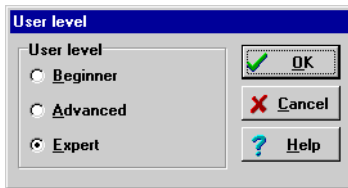

Fig. 4/1

2. Click “Beginner”.
3. Click “OK” to make the settings effective.

4.2 Loading preset parameter sets



If you are using Festo positioning axes with the Festo drive packages, you will find in this chapter the procedure for writing the tested parameter sets into the servo controller. If this is not the case, you can omit this chapter.

If you are using a Festo axis with Festo-ATP, you will require the following information for selecting a pre-prepared parameter file:

- the mounting position of the axis (horizontal or vertical)
- Which Festo DGE axis are you using?
- Which Festo drive package are you using?

With this information you can select the name of the appropriate parameter file from the table.

Example

Mounting position	horizontal
Axis	DGE-25-xxx-ZR
ATP	2.3 (motor: BSM63A275AA, gears $i = 4$)
Parameter file	23_25z_h.wpa



The parameter files can be found on the diskette supplied.

The parameter set contains all the important setting data to enable you to adapt the SEC-AC to a certain motor or application.

4. Basic settings

You can recognize parameter sets by the file name extension “*.wpa.”

The control parameters of the files for the ATPs are ‘all-round settings’, i.e. an optimization of the control parameters to your particular application is possible in most cases. See the chapter ‘Optimizing the motor’.

You must carry out the following steps in order to transfer a parameter set to the SEC-AC:

1. Select menu item [File]/[Parameter set]/[Read from file and store into servo].

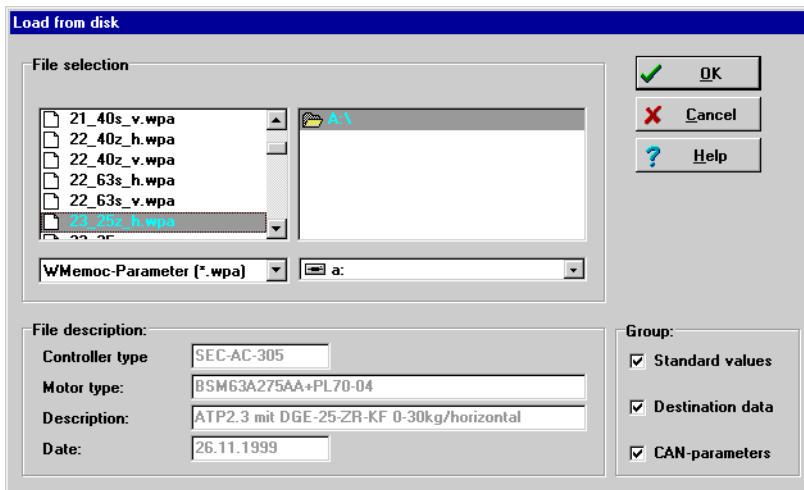

Fig. 4/2

2. Select the desired parameter set. Parameter sets end with “*.wpa.”

4. Basic settings

3. Under “Groups”: mark the ranges of the parameter set which are to be transmitted to the controller. Mark everything.
4. Click “OK” in order to transfer the parameter set to the SEC-AC.

The parameter set is now written into the SEC-AC. A bar indicates the status of the transmission. If the transmission is successful, the “File/Open” window will disappear and the following message will be displayed:

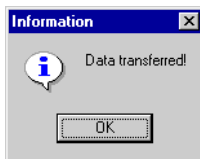

Fig. 4/3

The following window will be displayed if there is a fault in the data transmission:

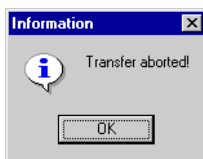

Fig. 4/4

In this case, faultless operation cannot be guaranteed. Repeat, therefore, data transmission of the parameter set.

4. Basic settings

If data transmission is successful, check the setting of the limit switch logic under [Parameters]/[Device parameters]/[Limit switch logic].

If your drive configuration is to run in speed-control mode, you must cancel the positioning module and the position controller in the command window. This concludes your software settings.

If your application is to run with position control, you must check the following settings:

- Position values:
[Parameters]/[Positioning]/[Destination parameters]
- Reference travel:
[Parameter]/[Positioning]/[Reference-position]



Please note

- Save the parameter set in the menu [Parameters]/ [Save parameters].
- Reset the SEC-AC by pressing the RES button.

The complete parameter set is now in the controller which is now ready to operate.

4.3 Setting the current limit values

The permitted current limit values for the motor must first be set.



If Festo parameter sets are used, the values adapted to the drive package are already pre-set.

1. Select menu item [Parameters]/[Motor data]. The menu shown below will be displayed.
2. Please refer to the manufacturer's data sheet or to the type plate on the motor for the maximum current values and for the rated current of the motor.

Motor Data

Limit value

Maximum current in A, rms value: 4,2 A

Nominal current in A, rms value: 2,2 A

The maximal current limits depend on the clock frequency of the power stage!

Power Stage

Number of pole pairs

Number: 3

Auto detect

Torque constant: 0,00 Nm/A

OK

Cancel

Help

Fig. 4/5

4. Basic settings



Please note

- The values to be entered for the maximum and rated currents are the **effective values**.

If the currents are too high, the motor will be damaged, as the permanent magnets in the motor will be demagnetized. The current limits specified by the manufacturer must not, therefore, be exceeded.

3. Enter the effective values for the maximum current and the rated current.
4. You can determine the number of pole pairs by activating the button “Auto detect”.
5. Entry of the correct torque constant is only relevant for the correct monitor display in the “Torque control” mode.
6. In order to exit the window, click the “OK” button.
7. Save the set values with [Parameters]/[Save Parameters].

The current limit values of the motor used are now made known to the SEC-AC.

4.4 Setting the regulator enable logic

In order to enable the controller, you must set the regulator enable logic. The controller enable logic decides on the conditions which must be fulfilled before the controller can be enabled.

1. Select menu item [Parameters]/[Device parameters]/[Regulator enable logic].

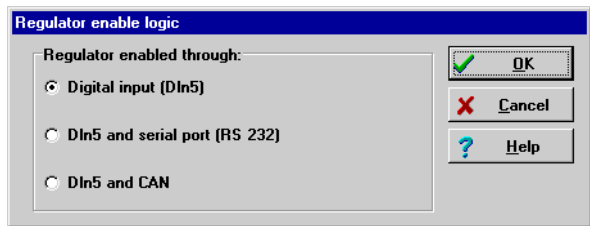

Fig. 4/6



With possibility no. 2, the “and” must be interpreted as “logical and”, i.e. the command over the serial interface is only effective when DIn 5 is active.

2. For the first commissioning select Only through digital input DIn5).
3. Click “OK”.

4.5 Setting the offset angle, phase sequence and number of pole pairs



A more detailed explanation of this theme can be found in the chapter Information on the offset angle, phase sequence and number of pole pairs.

The correct setting of the above mentioned variables is an important prerequisite for the correct functioning of the complete system.

The servo controller ascertains the named values automatically. Before this can be done, the motor must carry out a few test movements. It is therefore essential that the motor is operated in idling mode; no load may be coupled to the drive shaft.

In the case of Festo parameter sets, the values adapted to the drive package have already been set.



Caution

- Before starting the motor identification, you must set the current limit values (menu item [Parameter]/[Motor data]/[Current limits]), as otherwise the motor may be damaged.
- Do not enable the controller until the program requests this.

Carrying out the automatic identification

1. Select the command [Parameter]/[Motor data] from the menu bar.
2. Click the button “Auto detect” in the field “Number of pole pairs”.

4. Basic settings

3. The window shown below will be displayed. Click “OK”.
The motor shaft begins to turn; the complete procedure takes approximately 30 seconds.



Fig. 4/7

4. If identification is successful, the following window will be displayed:

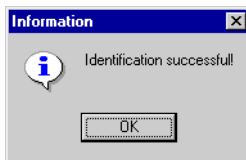

Fig. 4/8

5. Setting is then concluded. Save the settings with]Parameters]/[Save Parameters].

4.6 Setting the current controller



A more detailed explanation of this theme can be found in the chapter 'Information on the current controller'.

Amplification factor and time constant

The correct setting of the “current controller” is an important prerequisite for adapting the speed controller at a later stage to the motor used. The parameters to be set are the amplification factor “Gain” and the “time constant”.



The servo controller ascertains the named values automatically. Before this can be done, the motor must carry out a few test movements. It is therefore essential that the motor is operated in idling mode; no load may be coupled to the drive shaft.

In the case of Festo parameter sets, the values adapted to the drive package have already been set.

Carrying out the automatic identification

1. Activate the menu [Parameters]/[Device parameters]/[Current controller]. The menu shown below will be displayed.

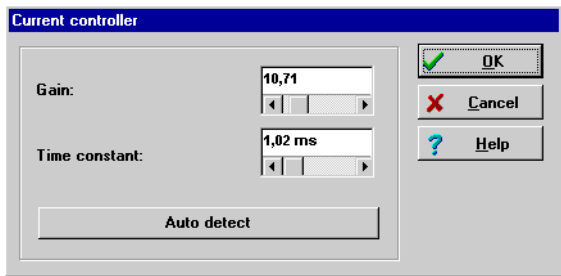

Fig. 4/9

2. Click “Auto detect”.
3. After carrying out automatic determination, click “OK”.
4. Save the settings with [Parameters]/[Save parameters].



If the automatic parameter determination is carried out again, the current regulator can and may deliver slightly different values.

4.7 Pre-setting the speed controller



In this step the speed controller is assigned with sensible basic values. The actual optimization takes place later in the further course of first commissioning (see chapter 'Optimizing the speed regulator').

In the case of Festo parameter sets, the values adapted to the drive package have already been set.

1. Select menu item [Parameters]/[Device parameters]/[Speed controller].

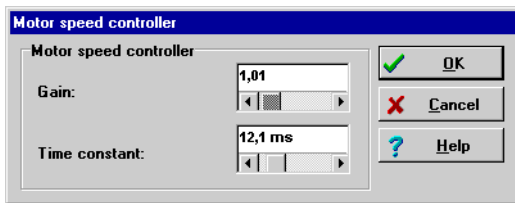

Fig. 4/10

2. Set the following output values:
amplification "1.0"
time constant "12.0 ms"
3. Click "OK" in order to exit the menu.
4. Save the settings with [Parameters]/[Save parameters].

4. Basic settings

4.7.1 Determining the limit switch logic

The SEC-AC can evaluate two limit switches which can be used for determining the positioning range. Each limit switch determines the positioning limit for a certain direction of rotation.

The limit switch logic describes the correlation between the logical and the physical positions of the limit switches. In technology, a normally-closed contact (protected against cable fracture) is usually used as a limit switch. However, with the SEC-AC it is also possible to use a normally-open contact. You can make this selection as follows:

1. Select menu item [Parameters]/[Device parameters]/[Limit switch logic].
2. Select the logic.

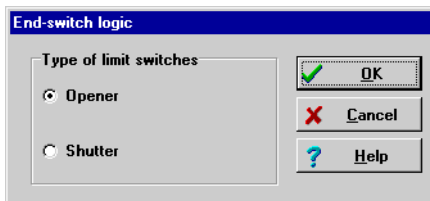

Fig. 4/11

3. Click "OK" .
4. If the limit switch logic is set correctly, the limit switch LEDs in the status window will light up, but only when the limit switches are actuated.

4.8 Selecting the operating mode

4.8.1 Summary

The SEC-AC can control the motor in

- speed-control mode
- position-control mode
- torque-control mode

The operating modes can be switched over in the “commands window”. This window can be found at the top left of the screen when the program starts.

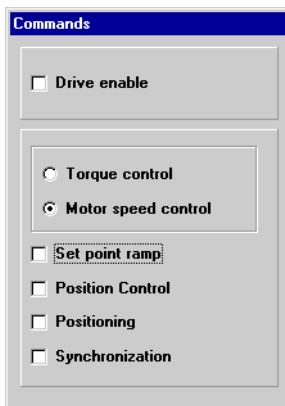

Fig. 4/12

You can switch from one operating mode to the other with the mouse.

Positioning and synchronization are alternative 'position-control modes'. "Position control" and "Motor speed control" must always be activated here. Only "Torque control" is activated selectively.

4. Basic settings

4.8.2 Torque control/speed control

With the torque-control mode, the mechanically loaded motor maintains the specified torque. The speed sets itself automatically depending on the load applied. With the speed-control mode, the motor maintains the specified speed irrespective of the load.

Speed control

The first commissioning requires first of all only the speed-control mode. In order to activate this, click the field “Motor speed control”.

4.8.3 Additional options

The additional options “Setpoint ramp” to “Synchronization” should not be active for the first commissioning (option not marked with a cross). By clicking the box, you can delete any crosses entered.

4.9 Setpoint-selectors

The SEC-AC can select one of six different setpoints by means of two setpoint-selectors. Both setpoints are then added together and are entered in the controller as the total setpoint (torque control or speed control). Both setpoint-selectors can be parametrized with the parametrizing program.

1. Select the menu [Setpoints].
2. Select the menu [Setpoint-selectors].

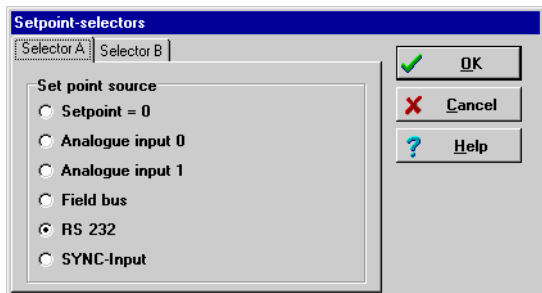

Fig. 4/13

3. Set “Selector A” to “RS232” (=serial interface).
4. Set “Selector B” to “Setpoint = 0”.
5. Click “OK”.

4.10 Configuring the actual value display

Speed and Motor current The parametrizing program offers you the possibility of displaying all the measured values numerically and simultaneously on the PC screen. For the first commissioning, you should display at least Speed and Motor current.

The actual value display can be set in the actual value menu (see below). All the values which are to be displayed must be marked with a tick. You can do this with the mouse key on the left. When clicked a second time, the selected actual value will be deleted from the display window (the tick will be deleted).

1. Click the menu [Actual values] in the upper menu bar.
2. Mark the entries “Motorspeed” and “Motor current” with a tick.

The actual value display now appears as follows:

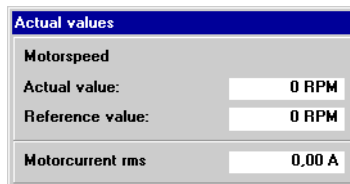

Fig. 4/14

4. Basic settings

First start and optimizing the motor

Chapter 5

5. First start and optimizing the motor

5.	First start and optimizing the motor	5-1
5.1	Testing the controller enable	5-3
5.2	Setting the actual speed value filter	5-6
5.3	Optimizing the speed controller	5-7
5.3.1	Summary	5-7
5.3.2	Carrying out the optimization	5-8
5.3.3	Strategies for optimizing	5-12
5.3.4	Further optimizations	5-15
5.4	Optimizing the positioning module	5-16
5.4.1	Setting the positioning module	5-16
5.4.2	Carrying out optimization	5-18

5. First start and optimizing the motor



Caution

You should not read this chapter before reading completely through the chapter “Basic settings”, especially the section on the current limit values of the current controller. Incorrect basic settings can cause damage to the servo controller/motor and to the mechanical drive.

5.1 Testing the controller enable



Caution

The motor can run at very high speeds during the controller enable.

- Block the controller enable, therefore, after each test and wait until the drive shaft comes to a stand again.

If the controller is parametrized incorrectly, it may be possible for you to bring the motor to a stand simply by switching off the final stage enable. If you have wired this input firmly and not included a switch, you must press the RES button.

Parameter/
Save parameterst

Before testing the controller enable, you must save the parameters and reset the controller. You can do this with the menu command [Parameters]/[Save parameters].

5. First start and optimizing the motor

In order to test the controller enable, proceed as follows:

1. Select the operating mode “Motor speed control” in the command window.
2. Set the setpoint-selectors “Selector A” to serial interface (“RS232”) and “Selector B” to “Setpoint = 0”.
3. Select menu item [Setpoints]/[Setpoint-value].
4. Specify a low speed (e.g. 100 rpm) (see figure below).
5. Switch on the final stage enable and the controller enable via the digital 24 V input.

The controller enable will be shown as a vertical bar in the 7-segment display of the SEC-AC. The six outer segments revolve in the form of running bars around the vertical bar, depending on the direction of rotation of the motor and on the speed.

When the controller is enabled, the motor must begin to turn. If this is not the case, there is either a fault or the controller has been parametrized incorrectly. In the table below, you will find typical faults and how to remedy them.

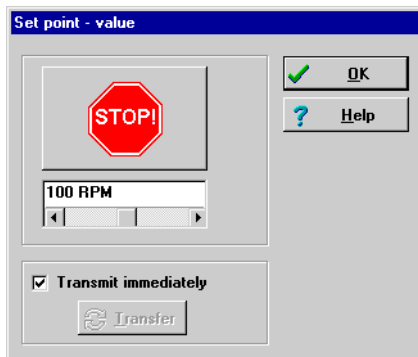

Fig. 5/1

5. First start and optimizing the motor

Fault	Remedy
No transverse bar appears in the display.	Check the 24 V power supply, se the controller enable logic.
An L, S or P appears in the display. These symbols flash.	The operating modes “position control”, “synchronizing” and/or “positioning“ are switched on. Deactivate these in the command window.
A two-figure error code flashes in the display.	Read how to rectify this error in the chapter “Diagnosis and Error treatment”.
The brake cannot be released.	Check plug connector X6 and the motor plug as well as the cable. Does the voltage source fulfil the specification? See sections ‘Power supply of the SEC-AC’ and ‘Power supply of parking brake’ in the chapter ‘Electromechanics’.
The motor develops a holding torque, it “locks” in various positions.	The number of pole pairs and/or the phase sequence is incorrect. Set the correct number of pole pairs (chapter ‘Setting the offset angle and the number of pole pairs’) and/or swap the motor phases.
The motor vibrates or runs unevenly.	The resolver offset angle and/or the controller parameters are not set correctly. Carry out the automatic identification again as described in the section ‘Setting the offset angle and the number of pole pairs’.



Please note

When connecting the motor phases, note that different manufacturers of servo motors specify different phase sequences. If necessary, you must swap the phases U and W.

5. First start and optimizing the motor

5.2 Setting the actual speed value filter

In order to improve the control behaviour, the actual measured speed value must be smoothed. This is accomplished with an actual speed value filter. The effective filter time constant can then be parametrized.

In the case of Festo parameter sets, the values adapted to the drive package have already been pre-set.

1. Select menu item [Parameters]/[Device parameters]/[Motor speed actual value filter].

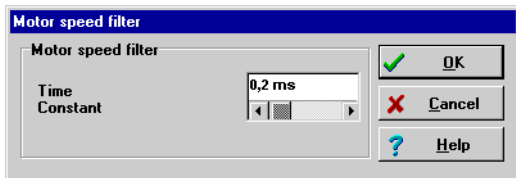

Fig. 5/2

2. Set the “Time constant” to “0.2ms”.
3. Click “OK”.
4. Save the settings with [Parameters]/[Save parameters].

As the actual speed value filter is entered as an additional time constant in the speed closed loop, it should be as small as possible. A value of 0.2 ms is therefore recommended for the first commissioning.

5. First start and optimizing the motor

5.3 Optimizing the speed controller

5.3.1 Summary

You can set the speed controller by specifying a setpoint jump.

With the PC oscilloscope function you can observe the reaction of the speed controller to the setpoint jumps and then set the control parameters.



The speed controller should be set so that only **one** overshwing of the actual speed value occurs. The overshwing should not be more than 10% above the nominal speed value. The falling edge of the overshwing should not or only just drop below the nominal speed value, before reaching the nominal speed value. This setting applies to most motors which can be operated with the SEC-AC. If a harder control behaviour is requested, the amplification of the speed controller can be further increased. The limit of amplification is reached when the drive starts to vibrate at high speeds. The amplification which can be achieved in the speed control circuit depends on the load conditions on the motor shaft. You must therefore check the setting of the speed controller again when the drive is fitted into place.



If you parametrize the speed controller when the motor shaft is in idling mode, you only have to adapt the control amplification, usually by increasing it, when the drive has been fitted.

5. First start and optimizing the motor

5.3.2 Carrying out the optimization



The implemented oscilloscope function of the parametrizing program can be used for optimizing the speed controller. More detailed information can be found in the chapter 'Extended functions of the parametrizing program'.

You have the possibility of reversing the motor over a certain path. It is important here that the motor is at first uncoupled from the mechanical drive.



Caution

The reversing operation can cause damage to a drive coupled to the motor. Therefore, disconnect the motor.

1. Start the oscilloscope by activating the menu item [Options]/[Oscilloscope].
2. Select the register card "Channels" and set the configuration as shown in the figure below.

5. First start and optimizing the motor

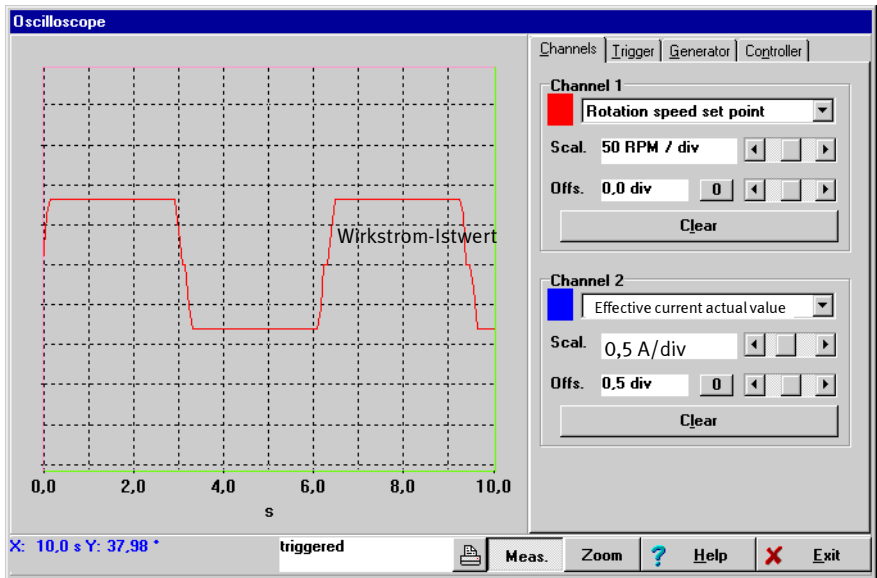

Fig. 5/3

3. Select the register card "Trigger" and set the configuration as shown in the diagram below.
4. Select the register card "Generator" and set the configuration as shown in the diagram below. Select a low reversing speed (less than 100 rpm).
5. Select the register card "Controller" and set the speed controller as shown in the diagram below.

5. First start and optimizing the motor

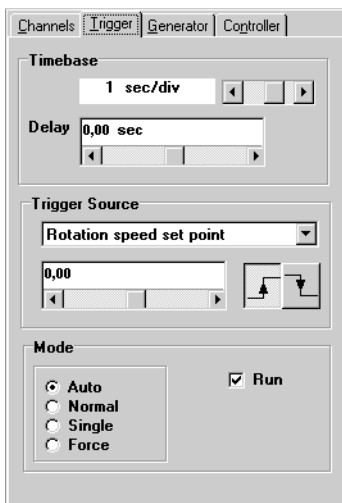

Fig. 5/4

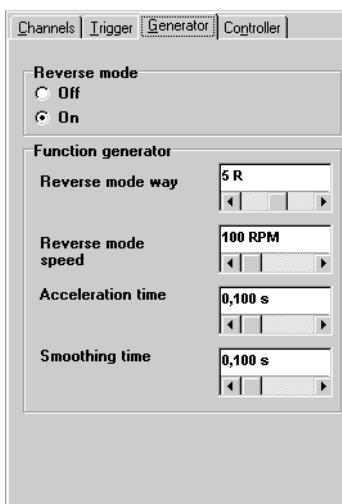

Fig. 5/5

5. First start and optimizing the motor

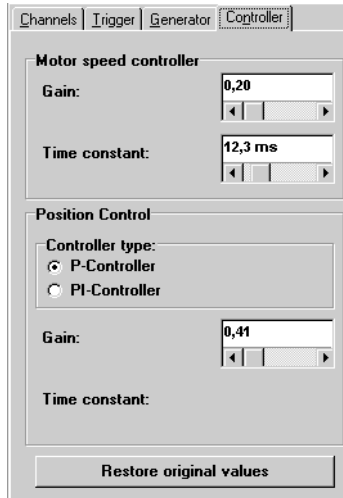

Fig. 5/6

6. Switch on the final stage enable and the controller enable. The motor now reverses within the specified limits.
7. Observe the oscillograms which are produced. Compare them with the samples in the next chapter. If the speed controller is set too 'soft' or too 'hard', use the measures specified. Experiment with various settings in order to find the optimum. An additional criterion is the actual current value which can set itself without a limit and without oscillation.



You can access the parameters of the speed controller by clicking the register card "Controller".

5. First start and optimizing the motor

5.3.3 Strategies for optimizing



Please note

A general rule is that you should not modify the numerical values for the amplification factor and for the time constant in large jumps, but only in small steps.

When the numerical values have been modified, two cases can arise:

- If the setting is too 'hard', the speed controller will become instable.
- If the setting is too 'soft', the drive will not be stiff enough. This will result in drag faults later in operation.

The speed control parameters are not independent of each other. A measured curve which looks different from test to test can have several causes. Therefore, modify **only one parameter** at a time. Start to vary and optimize the P-amplification with fixed, large time constants. Then reduce the time constants to an optimum.

In order to adapt the speed controller, increase the amplification until the motor vibrates, then reduce the amplification in small steps until the vibration disappears. Finally, reduce the time constant until vibration occurs, then increase the time constant in small steps until the controller is stable at "Set-point = 0" and is 'stiff' enough.

Due to their short cycle times, the controllers in the SEC-AC family do not begin to vibrate until unbalance is very rough, but tend to produce noise at an early stage depending on the degree of unbalance. You must then find a compromise between stiffness of the drive, stability and the production of noise.

5. First start and optimizing the motor

Case 1: Speed controller set too 'soft'

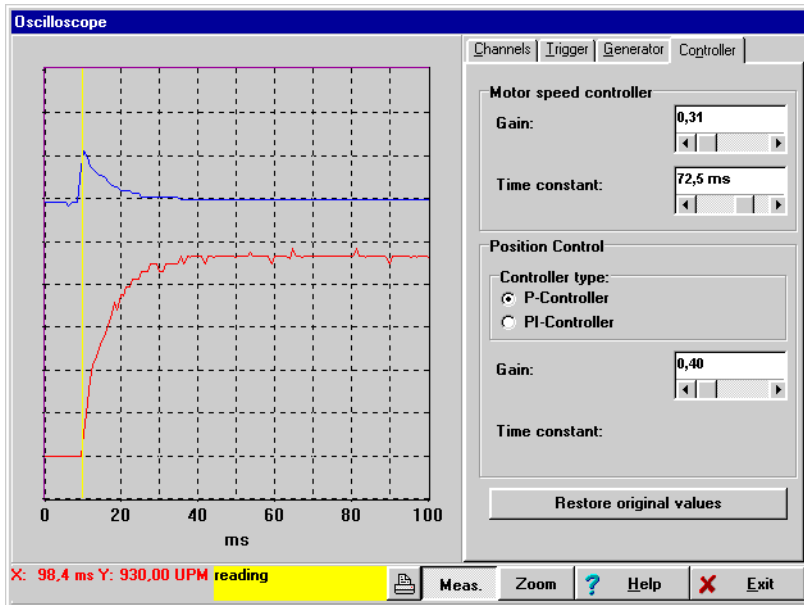

Fig. 5/7

Remedy

Increase the amplification factor by 2 to 3 tenths of a point /
reduce the time constant by 2 to 3ms.

5. First start and optimizing the motor

Case 2: Speed controller set too 'hard'

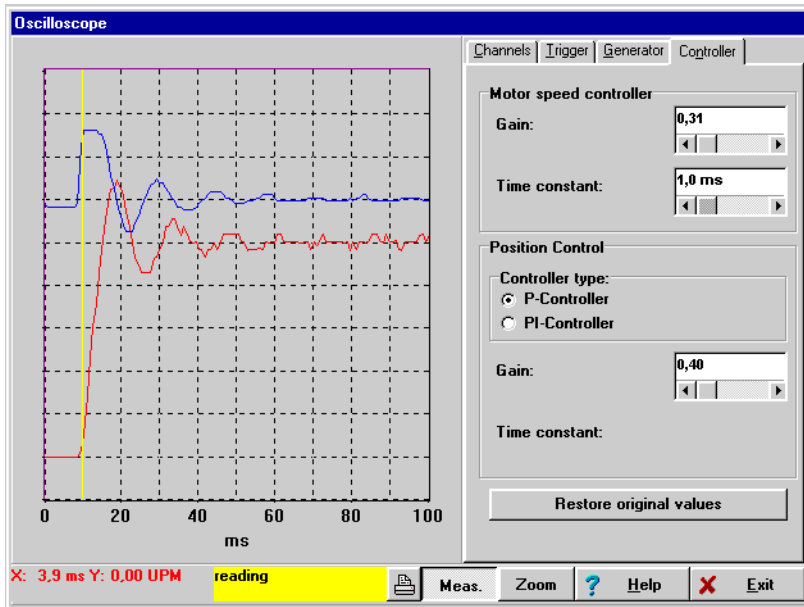

Fig. 5/8

Remedy

Reduce the amplification factor by 2 to 3 tenths of a point /
increase the time constant by 2 to 3ms.

5. First start and optimizing the motor

Case 3: Speed controller set correctly

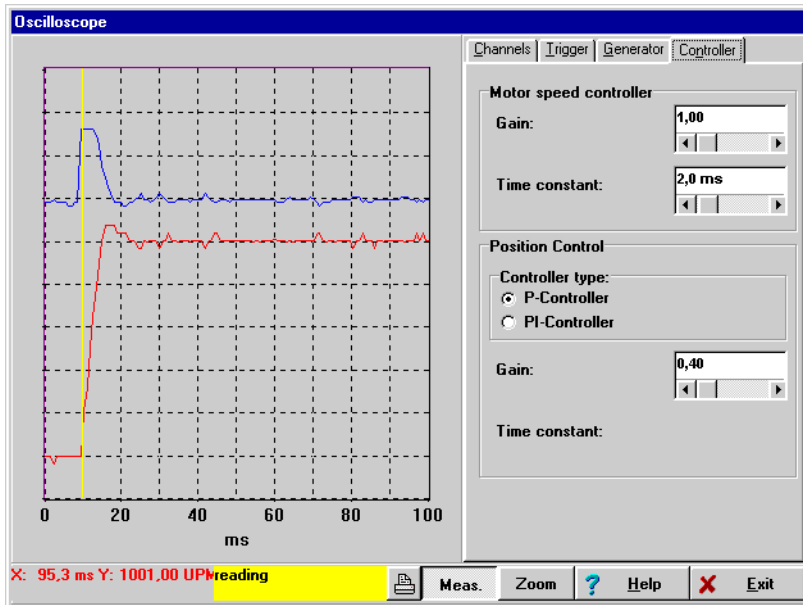

Fig. 5/9

5.3.4 Further optimizations

When you have adapted the speed controller, you can fit the motor into the system. You must then check the speed controller again. Usually, the amplification factor must be increased due to the higher system load.

If you are using the SEC-AC as a speed controller, the setting of the controller will suffice for your application. If you are using the SEC-AC for positioning tasks, you must also parametrize the positioning module in addition to adapting both the current and speed controller. Characteristic values for a positioning movement are positioning times, positioning accuracy and position overshoot at the destination.

5. First start and optimizing the motor

5.4 Optimizing the positioning module

5.4.1 Setting the positioning module

From the difference between the nominal and the actual positions, the positioning module forms a speed result which is transmitted as the setpoint to the speed controller.

PI-controller/P-controller

The positioning module can only be operated in conjunction with the position control or the synchronization control. Although it is a “PI-controller” with parametrizable input and output limits, it should be operated only as a “P-controller”. The operating mode “PI-controller” is reserved for special applications.



Please note

Correctly set current and speed controller are a prerequisite for adapting the positioning module.

The positioning module can be parametrized in one of two methods:

- via the menu item [Parameters]/[Positioning control]
- via the menu item [Options]/[Oscilloscope], Register card “Controller.”



Please note

Do not open both menus at the same time, otherwise parametrization will be inconsistent.

5. First start and optimizing the motor

Parameter/
Positioning module

The command [Parameters]/[Positioning controller] generates the following window:

Position Control

Controller type:

P-Controller

PI-Controller

Controller:

Gain: 0,41

Time constant: 6,6 ms

max. trailing error:

positive: 50,00 °

negative: -50,00 °

max. correction speed:

positive: 487 RPM

negative: -487 RPM

OK

Cancel

Help

Fig. 5/10

Controller type

In the field “Controller type”, you can determine whether the positioning module is to operate as a P-controller or a PI-controller. Select here the operating mode “P-controller”.

Amplification

In the field “Gain”, you can specify the amplification factor of the controller.

Time constant

In the field “Time constant”, you can specify the time constant (only with the PI-controller).

5. First start and optimizing the motor

Drag fault

In the field “Max. trailing error”, you can set the limits for recognizing drag faults. The limits can be set at maximum half a motor revolution. With the aid of the drag fault monitoring you can ascertain whether the dynamic position deviation has exceeded a certain value during a positioning movement. See also the chapter ‘Extended functions of the parametrizing program’, section Parameter/Device parameter/Digital outputs’.

Correction speed

In the field “Max. correction speed”, you can limit the maximum output size of the positioning module. This should be set at first at approximately ± 500 rpm.

5.4.2 Carrying out optimization

Please observe also the instructions in the previous chapter.



Please note

Optimization of the positioning module can also be carried out in the reversal mode. Make sure that the mechanical parts can turn freely and that the drive cannot be damaged. In addition to observation of the rotor position, observation of the nominal speed value and the drag fault also represents a possibility of optimizing the positioning module. The drag fault must disappear as soon as possible during the initial response, but must not tend to oscillate (see also the diagrams below).

Overswing of the rotor position can be further minimized in later operation by smooth acceleration.

5. First start and optimizing the motor

The following steps are necessary for optimizing the positioning module:

- | | |
|--|---|
| Speed control/Positioning/Position control | 1. Activate the operating modes “Motor speed control”, “Positioning“ and “Position control“ in the command window. |
| Options/Oscilloscope | 2. Start the oscilloscope under menu item: [Options]/[Oscilloscope]. |
| Channel | 3. In the register card “Channel“ set: “channel 1 = trailing error; channel 2 = actual speed value”. |
| Generator | 4. In the register card “Generator“ set: “reverse mode = OFF; reverse mode way = e.g. 5 turns; reverse mode speed (approx. 20%) = half the rated speed; acceleration time = 0, smoothing time = 0. |
| Trigger | 5. In the register card “Trigger” set: “time base = 100 ms; delay = -200 ms; trigger source = rotation speed set-point; trigger level = half the reverse speed; falling trigger edge; mode = normal”; “run” activated. |
| Controller | 6. Switch to the register card “Controller“ and set the controller type on the positioning module to P-controller” and the amplification to “0.5”. |
| Generator | 7. Start the reverse procedure by switching again to the register card “Generator“ and set: “reverse mode = ON”. The motor should now operate in reverse.
8. In order to optimize, evaluate the speed and the rotor position during the stop process. If the initial speed adjustment takes too long, the amplification must be increased. |

5. First start and optimizing the motor

If the speed begins to oscillate during the stop process, the amplification must be reduced, See also the diagrams below.

Case 1: Drag fault is reduced too slowly →
Increase amplification of positioning module

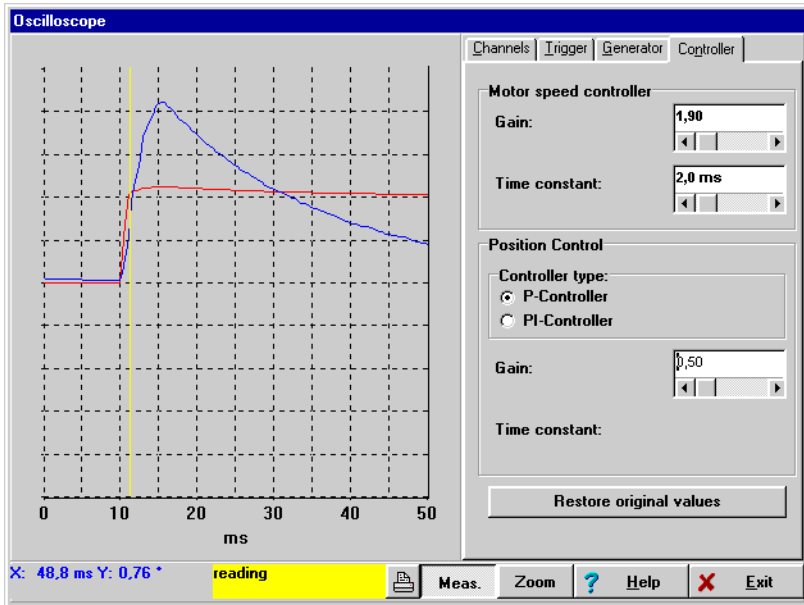

Fig. 5/11 Lower (smaller) curve: actual speed value
Upper (pointed) curve: trailing error

5. First start and optimizing the motor

Case 2: Tendency of drag fault and nominal speed to oscillate
→ Reduce amplification of positioning module

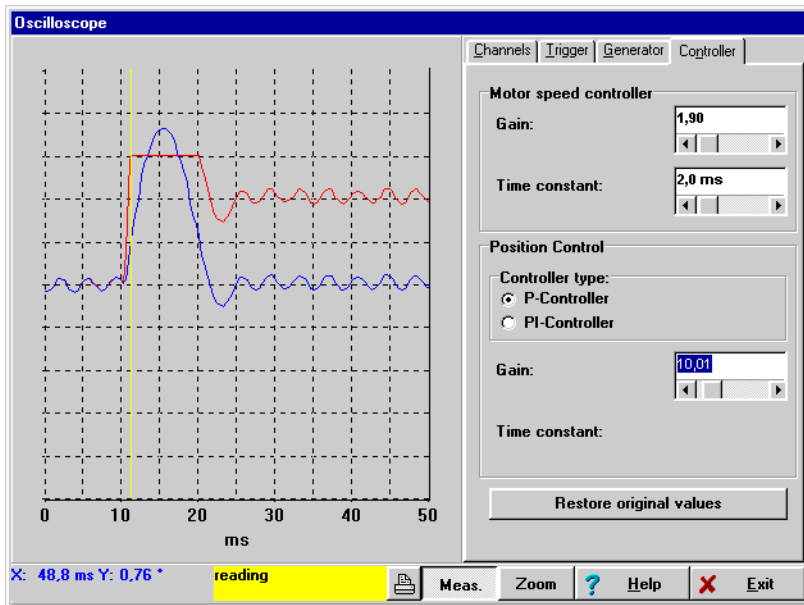

Fig. 5/12

5. First start and optimizing the motor

Case 3: Positioning module set correctly

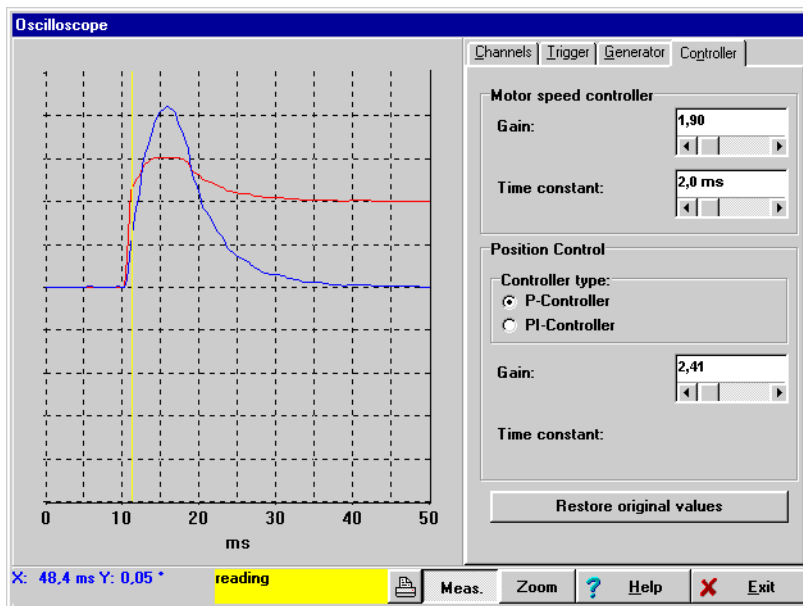

Fig. 5/13

Working with parameter sets

Chapter 6

6. Working with parameter sets

6.	Working with parameter sets	6-1
6.1	General information	6-3
6.2	Loading and saving parameter sets	6-5
6.3	Offline parametrizing	6-6

6.1 General information



In order that the servo controller can operate the motor faultlessly, the characteristic values described in the chapter 'Basic settings' must be set correctly.

Parameter/
parameter set

The individual characteristic value is described in the following as a “parameter”; all the parameters together for a controller/motor combination are described as a “parameter set”.

The drawing below shows how parameter sets are managed.

- 1 Read out / Modify
- 2 Load standard parameter set
- 3 Save parameter set
- 4 Reset parameter set
- 5 Read file and store in servo
- 6 Read from servo and store in file

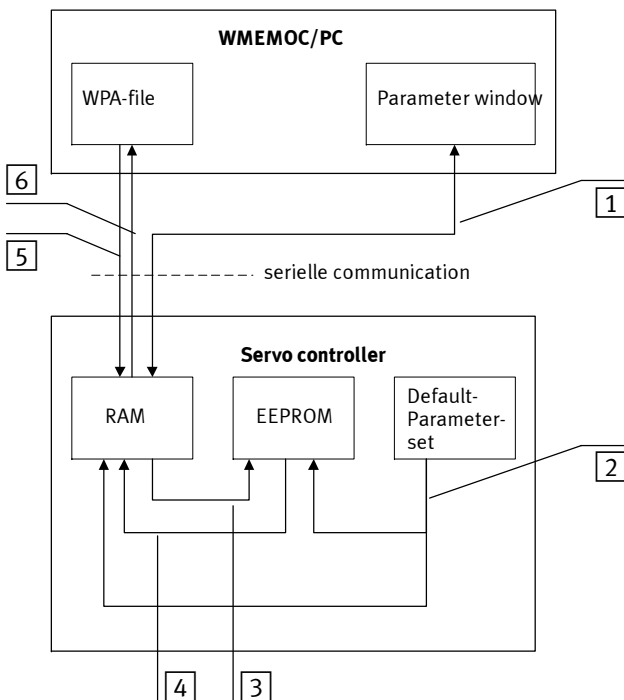

6. Working with parameter sets

Parameters/ Save parameters

The current parameter set of the servo controller is available in the RAM memory (RAM = Random Access Memory). The RAM will lose its contents if the power supply is switched off. In order to save the parameter set permanently, it can be copied into the EEPROM with the command Save parameter/parameter set. The EEPROM (Electrical Erasable Programmable Read Only Memory) will also lose its contents if the power supply is switched off.

Each time the controller is reset, the contents of the EEPROM are copied into the RAM. A controller “reset” can be triggered when:

- the 24V power supply is switched off and then on again
- the reset button on the servo controller housing is pressed
- the command “RESET” is entered in the “transfer” window of the parametrizing program (see chapter ‘Transfer window’).

Standard parameter set

Every servo controller possesses furthermore a standard parameter set. This parameter set is integrated in the firmware and cannot be overwritten. If, for reasons unknown, parametrization is not successful, the standard parameter set can be loaded, in order to provide an ‘organised basis’.

You can activate the standard parameter set by entering the command DSP in the transfer window of the parametrizing program (see the chapter ‘Functions of the parametrizing program’, section ‘File/Transfer window’). The parameter set will then be copied into the EEPROM and the RAM.

6.2 Loading and saving parameter sets

*.wpa

With reference to the previous chapter, it is also possible to save and manage parameter sets externally (i.e. on the hard disc or on a diskette). For this purpose, the parameter set is read by the servo controller and saved in a file (or read by a file and saved in the servo controller). The file extension for the parameter files on the PC is “*.wpa”. Writing and reading the WPA files is carried out in the parametrizing program in the menu items:

- [File]/[Parameter set]/[Read from servo and store in file]
- or
- [File]/[Parameter set]/[Read from file and store in servo]



Motor type/Description

Further information can be found in the chapter 'Loading basic settings/ preset parameter sets'.

Please note that, when writing a parameter set into a file, you have the possibility of filling in the fields “Motor type” and “Description”. We urgently recommend you to do this, in order to avoid later confusion of parameter sets. A sensible name should also be chosen for the parameter set.



WPA files can be sent per diskette, CD, E-mail.

6.3 Offline parametrizing

The parametrizing program offers you the possibility of accessing parameter sets, even when there is no serial communication with the servo controller. The requirement here is that there must be an appropriate WPA file (see previous chapter). You can also :

- read out control parameters
- modify control parameters
- save modified values in the same or in another WPA file.

In order to make the modifications effective, you must load the modified parameter set into the servo controller (see previous chapter).

- 1 Read out / Modify
- 2 Load standard parameter set
- 3 Save parameter set
- 4 Reset parameter set

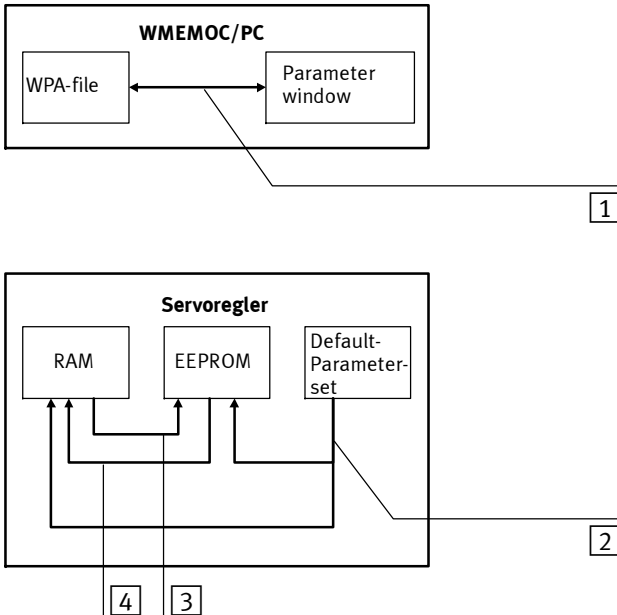

Fig. 6/14 Prinzip of Offline-Parametrizing

6. Working with parameter sets

Options/
Offline parametrizing

In order to activate the offline parametrizing, click the menu item [Options]/[Offline parametrization].

You will be asked to specify the WPA file which is to be opened. Select the desired file.

The file has been created for a specific type of controller. If it is to be used for a different controller type, select the new controller type.



Caution

If you use a WPA file for a different type of controller, you should always check the settings for rated current, maximum current, current controller and speed controller, as there is a danger that the servo controller/motor may be damaged.

The parametrizing program for offline parametrizing differs slightly from online parametrizing as follows:

- certain menus (e.g. Firmware download) are blocked

File/Parameter set

- the menu [File]/[Parameter set] has other submenus:

- [Open file]

- [Save file]

- [Save file as...]

- When you exit the program, you will be asked if you wish to save the parameter file just opened.

6. Working with parameter sets

Options/
Online parametrizing

You can conclude offline parametrizing by clicking menu item [Options]/[Online parametrizing].

Whether the offline or online parametrizing is active at the moment can be seen in the icon bar underneath the menu bar.

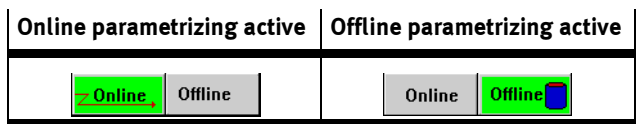

The mode currently active is shown in green.

Information on the automatic identification

Chapter 7

5. Information on the automatic identification

7.	Information on the automatic identification	7-1
7.1	Information on the offset angle, phase sequence and number of pole pairs	7-3
7.1.1	Summary	7-3
7.1.2	Automatic identification	7-4
7.2	Information on the current controller	7-5

5. Information on the automatic identification

7.1 Information on the offset angle, phase sequence and number of pole pairs

7.1.1 Summary

The offset angle is the angle between the mechanical zero position of the resolver used and the electrical zero position of the rotor, resulting from the arrangement of the motor windings.

The setting of the correct offset angle is an important prerequisite for the faultless functioning of the complete drive. The angle between the resolver and the electrical zero position of the motor windings is generally the same for all the motors of a certain class from one manufacturer. If, therefore, you have ascertained the offset angle of a certain type of motor from a particular manufacturer, you can use the offset angle for all other motor types from the same manufacturer, providing these motor types have the same number of pole pairs.

Correct setting of the offset angle is necessary for the following reasons:

- for implementing the set nominal speed and torque
- for optimizing the degree of effectiveness of the complete drive

If the number of pole pairs set in the servo controller is not matched to the motor, there can be no correct commutation of the phase currents. In this case, the motor will not run smoothly. It will lock in certain positions and develop a strong holding torque.

5. Information on the automatic identification

7.1.2 Automatic identification

Most problems arise in setting the resolver offset angle and in cabling with the correct phase sequence. The phase sequence problem arises because there are no uniform assignments or designations and each manufacturer makes his own decision (for both motor and resolver phase sequences). In addition, the number of pole pairs of a motor is not usually noted on the type plate.

The SEC-AC ascertains these values automatically. The following parameters are recognized:

- the number of pole pairs of the motor
- the sequence of the motor phases (UVW)
- the sequence of the resolver phases (swapping + and -, swapping sine and cosine), carrier and track may not be swapped, neither may the tracks be swapped amongst each other (the pairs must always remain together)
- the offset angle of the resolver

In order to determine the motor parameters, the motor must carry out a few test movements. It is therefore necessary for the motor to be operated in idling mode. No load may be coupled to the shaft.

5. Information on the automatic identification

7.2 Information on the current controller

The current controller is used for optimally specifying the nominal current in the windings of the connected motor. The setting of the current controller depends on the electrical characteristics of the motor. The inductivity of the motor and the internal resistance of the motor windings determine the setting of the current controller.

The correct setting of the current controller is an important prerequisite for adapting the speed controller at a later stage to the motor used.

The parameters to be set are the amplification factor and the time constant.

Amplification factor

The amplification factor determines the intensity with which the actual value is adjusted without delay to the setpoint. Higher amplification factors cause a 'harder' reaction of the current controller to modifications of the setpoint.

Current controller which are set too 'hard' also cause instability in the current flow to the motor. In extreme cases this can be clearly heard as a loud whistling.

Time constant

The time constant determines the speed at which the actual current value is adjusted stationarily to the nominal current value. Higher time constants cause a softer reaction of the current controller to modifications of the setpoint.

Current controller which are set too 'soft' lead to the dynamics of the motor not being used.

The Festo SEC-AC controller ascertains the optimum current control parameters automatically.

5. Information on the automatic identification



Please note

If a current controller is set too 'hard', this can cause considerable overswing of the motor current in excess of the setpoint. There is then a danger of the motor being damaged as the permanent magnets in the motor will be demagnetized.

Standard applications and settings of the parametrizing program

Chapter 8

8. Standard applications and settings of the parametrizing program

8.	Standard applications and settings of the parametrizing program	8-1
8.1	Layout of the controller	8-3
8.2	Torque-control mode	8-4
8.3	Speed-control mode	8-6
8.4	Positioning	8-8
8.4.1	Reference travel	8-9
8.4.2	Setting positions	8-14
8.4.3	Setting digital outputs	8-20
8.5	Master-slave operation	8-21
8.5.1	Speed-synchronous positioning	8-22
8.5.2	Position-synchronous movement	8-26
8.6	Timing the digital signals	8-29
8.6.1	Digital inputs	8-29
8.6.2	Timing the final stage enable and controller enable	8-30
8.6.3	Timing the limit switches	8-32
8.6.4	Timing the control signals for the positioning module	8-33
8.6.5	Feedback messages from the servo controller	8-37

8.1 Layout of the controller

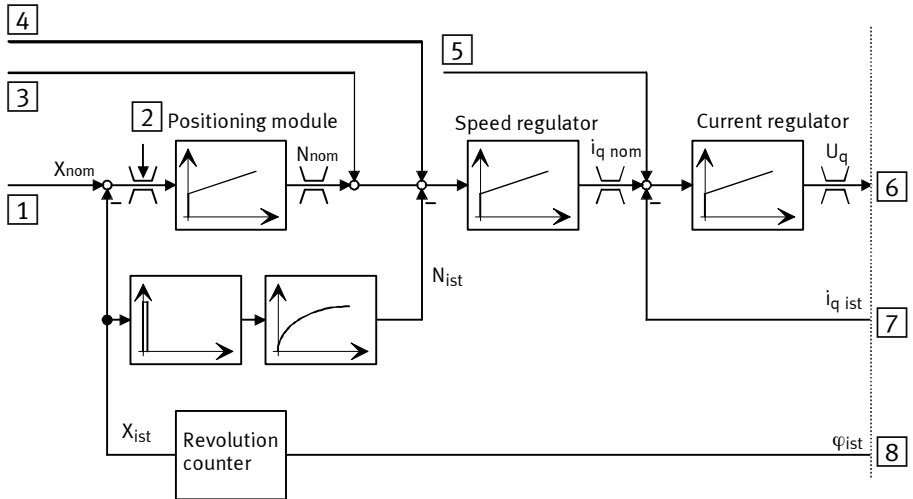

- | | |
|-------------------------------------|---|
| 1 From position setpoint management | 5 From torque management |
| 2 Trailing error recognition | 6 Coordinate transform. and modulator |
| 3 From positioning control | 7 Current measurement and coordinate transformation |
| 4 From speed setpoint management | 8 Angel encoder evaluation |

Fig. 8/1

The diagram shows the basic control layout of the SEC-AC. The current controller, speed controller and positioning module are arranged in the form of a cascade control. Due to the rotor-orientated control principle, the current can be specified separately in the effective share (i_q) and the idle share (i_d). There are therefore two current controllers, each of which has been designed as a PI controller. In Fig. 8/3, the i_d -controller is not shown for reasons of clarity. The speed controller and the positioning module have also been designed as PI controller and can be switched on/off individually.

8. Standard applications and settings of the parametrizing program

8.2 Torque-control mode

Torque-control mode does not occur very often, as the motor can reach infinitely high speeds when there is no load. In torque-control mode a certain nominal torque, that the servo motor generates in the motor, is specified. As the torque is proportionate to the motor current, only the current controller is active in this operating case. Below is a diagram explaining the control process in simplified form.

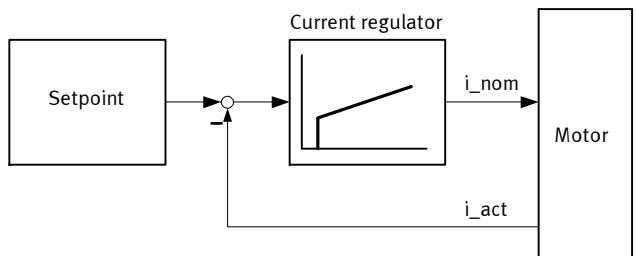

Fig. 8/2

In order to set the torque-control mode, you must configure the command window as follows:

Command window	
Torque control	ON
Speed control	OFF
Setpoint ramp	Optional*)
Positioning module	OFF
Position control	OFF
Synchronization	OFF
*) If the setpoint ramp is actuated, setpoint jumps will be converted into ramp functions. For parametrizing these ramps, please refer to the chapter 'Extended functions of the parametrizing program', section 'Parameters/ Device parameters/SWI ramp'.	

8. Standard applications and settings of the parametrizing program

For the various possibilities of specifying the setpoint see the chapter 'Extended functions of the parametrizing program', section 'Setpoint/Setpoint specification'.

Options/Torque

The actual setpoint can be specified in A or Nm. This can be set with menu item [Options]/[Torque in Nm]. A tick in front of the menu item means that the torque is calculated in Nm. The menus for the actual and setpoints then adjust themselves automatically to the new unit.

Torque constant

If the torque is to be specified in Nm, the torque constant, i.e. the conversion factor between current and torque, must be made known.

Parameters/Motor data

The torque constant is entered in the menu [Parameters]/[Motor data] and can usually be ascertained from the specifications on the type plate on the motor. The rated torque must be divided here by the rated current.



Please note

A torque constant of "0 Nm/A" is not permitted, if [Torques in Nm] is activated.

8. Standard applications and settings of the parametrizing program

8.3 Speed-control mode

In speed-control mode a certain nominal speed is specified. The servo controller tries to specify this speed to the motor. The actual speed is attained from the information in the internal incremental sensor. The adjusting variable from the speed controller is passed on to the current controller.

The diagram below shows this process in simplified form.

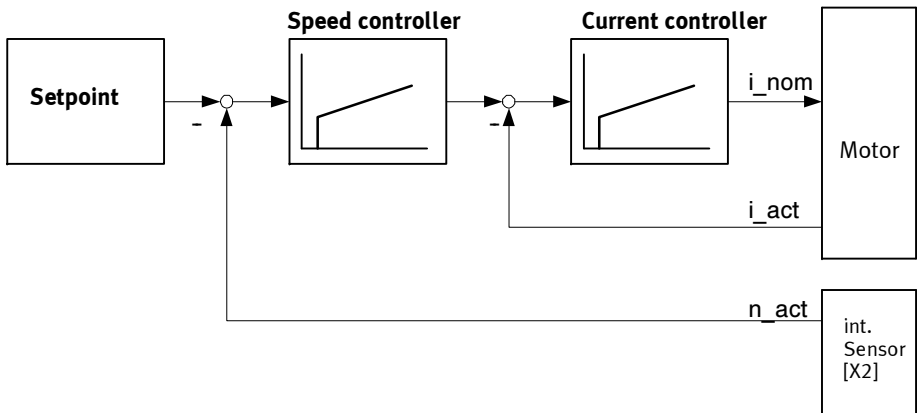

Fig. 8/3

8. Standard applications and settings of the parametrizing program

In order to set the speed-control mode, you must configure the command window as follows:

Command window	
Torque control	OFF
Speed control	ON
Setpoint ramp	Optional
Positioning module	OFF
Position control	OFF
Synchronization	OFF



If the setpoint ramp is actuated, setpoint jumps will be converted into ramp functions. For parametrizing these ramps, please refer to the chapter 'Extended functions of the parametrizing program', section 'Parameters/Device parameters/SWI ramp'.



When a specified speed is reached, it is possible to set a digital output which sends a reply message to a higher-order controller or which triggers other actions. See also the chapter 'Extended functions of the parametrizing program', section 'Parameters/Device parameters/Speed signal'.

8. Standard applications and settings of the parametrizing program

8.4 Positioning

In the positioning mode, a certain position is specified to which the motor must move. The current position is attained from the information from the internal incremental sensor. Deviation from this position is processed in the positioning module and passed on to the speed controller. The diagram below shows this process in simplified form.

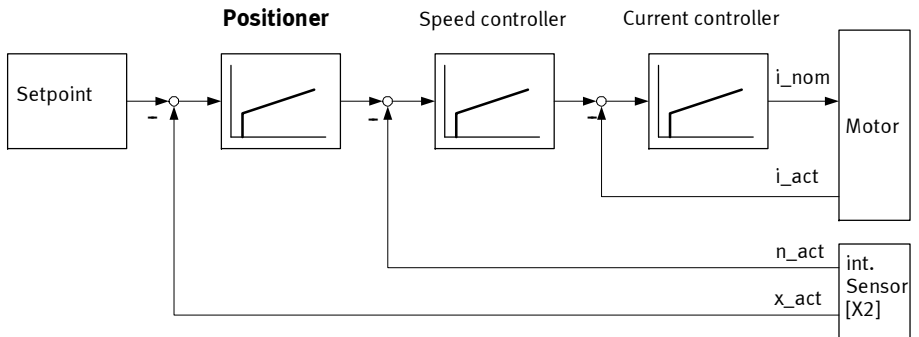

Fig. 8/4

In order to set the positioning mode, you must configure the command window as follows:

Command window	
Torque control	OFF
Speed control	ON
Setpoint ramp	No significance
Positioning module	ON
Position control	ON
Synchronization	OFF



Please note

The setpoint ramp is not active in the positioning mode.

8. Standard applications and settings of the parametrizing program

8.4.1 Reference travel



The settings for the command window can be found in the chapter 'Standard applications and settings of the parametrizing program', section 'Positioning'.

The reference position is the zero point to which all further positions refer.

When the 24 V power supply is switched on or after a RESET, the current resolver position is used as the actual position. The zero position which arises therefrom is used as the reference position if reference travel is not carried out.

Normally, reference travel is carried out in order to determine the reference position. The drive usually moves to the limit switch and evaluates this signal as described below. You can start reference travel with an explicit command via the serial interface, field bus or automatically with controller enable.

Reference position / Reference travel

In most applications in which the servo controller works in the positioning mode, an agreement must be made on a zero position to which the positioning module can refer. This position is called the reference position and must be determined each time the controller is switched on. This takes place in the so-called 'reference travel'.

8. Standard applications and settings of the parametrizing program

Parameters/Positioning/
Reference position

The reference travel can be parametrized in the menu [Parameters]/ [Positioning]/[Reference position]. The following window will be shown:

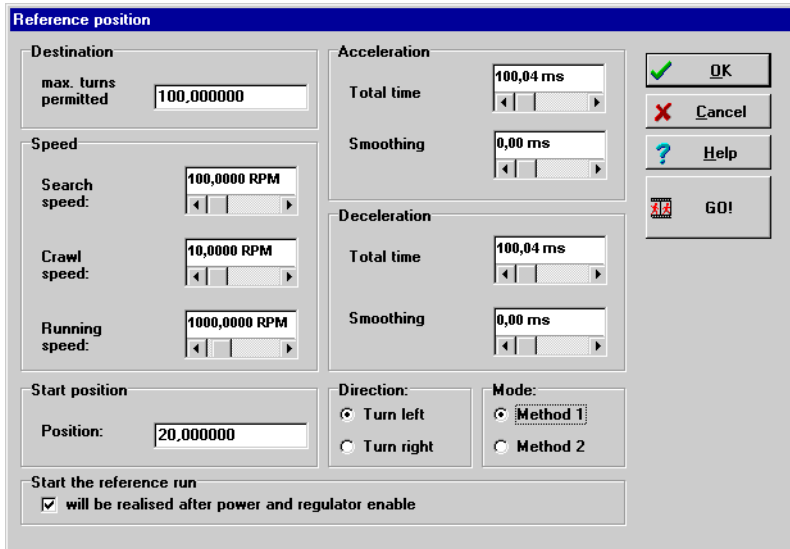

Reference position

Destination
max. turns permitted: 100,000000

Speed
Search speed: 100,0000 RPM
Crawl speed: 10,0000 RPM
Running speed: 1000,0000 RPM

Start position
Position: 20,000000

Acceleration
Total time: 100,04 ms
Smoothing: 0,00 ms

Deceleration
Total time: 100,04 ms
Smoothing: 0,00 ms

Direction:
 Turn left
 Turn right

Mode:
 Method 1
 Method 2

Start the reference run
will be realised after power and regulator enable

OK
Cancel
Help
GO!

Fig. 8/5

Maximum search path

During reference travel, the motor turns until the limit switch signal is activated. A maximum search path can be specified. If the limit signal is not recognized within this search path, the servo controller will send an error message.

8. Standard applications and settings of the parametrizing program

Search/crawl/running speed	The motor now moves to the limit switch at the set search speed. At the limit switch it reverses and moves back slowly from the switch at creep speed. In this way the contact threshold can be accurately defined. The drive then moves to the actual reference position at positioning speed.
Position	<p>The actual reference position is situated at a defined offset from the limit switch position. This can be set in the field “Position”.</p> <p>If “Mode” “Method 1” is active, the drive will move to the reference position via the offset specified in the field “Position” after the falling edge of the limit switch evaluation.</p> <p>If “Mode” “Method 2” is active, the drive will reference at the first zero pulse of the position sensor after the falling limit switch edge. As in method 1, it will then move to the reference position via the offset specified in the field “Start Position”, “Position”. The figure below explains the course of reference travel using the example of a linear axis.</p>

8. Standard applications and settings of the parametrizing program

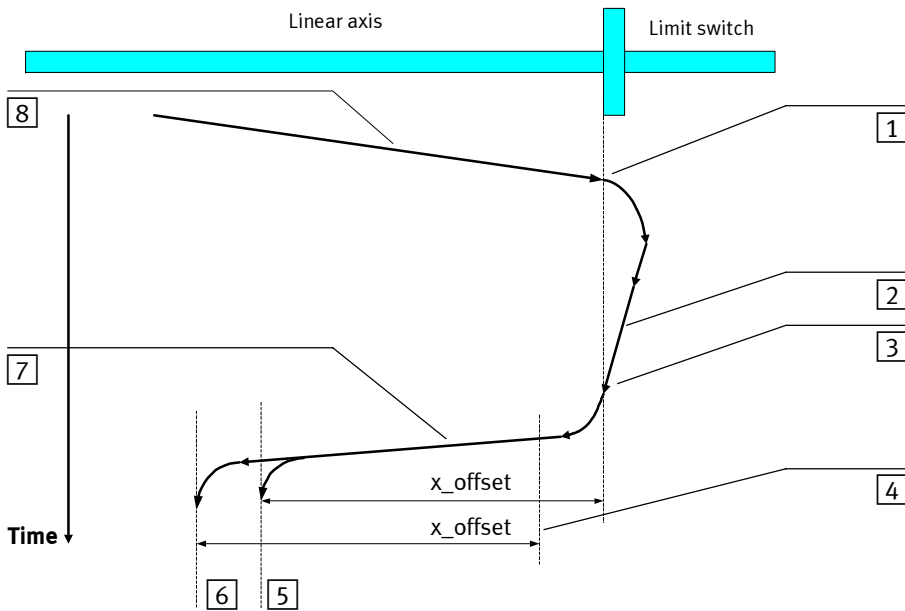

- | | |
|---------------------------------------|---|
| 1 Limit switch responds | 5 Reference position Method 1 |
| 2 Move back with v_{craw} | 6 Reference position Method 2 |
| 3 Limit switch inactive | 7 Move to position with v_{move} |
| 4 Zero pulse of puls generator | 8 Movement with v_{search} to limit switch |

Fig. 8/6

8. Standard applications and settings of the parametrizing program

Acceleration/ Deceleration	In the fields “Acceleration” and “Deceleration“ you can define the acceleration and braking ramps. They influence all three movement processes equally (search, crawl, running).
Direction	In the field “Direction“ you can determine the direction of search and thereby select the limit switch to be used for reference travel.
Start reference travel	<p>The field “Start reference run” will be triggered after final stage enable and controller enable. Mark a cross if reference travel is to be started automatically at the first controller enable. After a second controller enable, reference travel will not be started again until the final stage enable is cancelled.</p> <p>In this way, reference travel is not necessary after controller block and new enable.</p> <p>You can use the “GO!” button to trigger reference travel.</p>

8. Standard applications and settings of the parametrizing program

8.4.2 Setting positions

The servo controller possesses a table of 16 positions and individual positioning profiles which can be used for parametrizing destinations in advance. There is also a position block for the RS232 interface.

Parameters/Positioning/
Destination parameters

You can parametrize the destination positions in the menu [Parameters]/ [Positioning]/[Destination parameters]. The following window will appear:

The screenshot shows a software window titled "Destination 0" with a blue header bar. The window is divided into several sections. On the left, a "Select" section contains radio buttons for "CAN-BUS", "RS-232", and "Pos 0" through "Pos 15". The "Pos 0" option is selected. The "Destination" section has a "Position:" text field containing "0,000000 R". The "Speed" section has "Running speed" (3000,0000 RPM) and "Final speed" (0,0000 RPM) fields. The "Torque feed forward" section has a "Factor" field containing "0". The "Positioning run" section has radio buttons for "relative", "Relative to last destination", and "absolute". The "Start during positioning run" section has radio buttons for "wait for End of positioning run", "Interrupt actual positioning run", and "Ignore start command". The "Acceleration" section has "Total time" (102,1 ms) and "Smoothing" (29,9 ms) fields. The "Deceleration" section has "Total time" (102,1 ms) and "Smoothing" (30,7 ms) fields. The "Messages" section has "Remaining distance" (0,000000 R) and "Remaining time" (0,0 ms) fields. The "Options" section has a "Synchronized" checkbox. On the right side, there are buttons for "OK", "Cancel", "Help", "Copy", and "GO!".

Fig. 8/7

Select

In the field "Select" you can select the destination to be parametrized.

Destination, Position

In the field "Destination," "Position" you can specify the destination position. The destination position will be interpreted differently, depending on whether absolute or relative positioning has been selected. (See field "Positioning run")

8. Standard applications and settings of the parametrizing program

Speed

In the field “Speed“ you can specify the speed at which movement to the destination is to be carried out.

The “final speed” specifies the speed at which the drive is to reach the destination position. In most cases this is zero. If a final speed not equal to zero is set, the positioning profile will be calculated so that the drive continues to move at the specified speed when the destination is reached (in order then to process the next positioning command).

The figure below shows a positioning profile in which the final speed is set at “v1” when position 1 is reached.

- 1 Position 1
- 2 Position 2

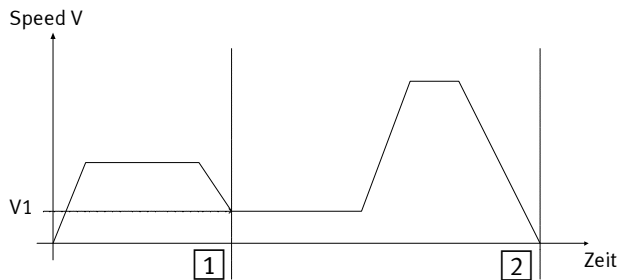

Fig. 8/8

Acceleration/ Braking time

In the fields “Acceleration“ and “Deceleration“ you can parametrize the ramps for accelerating and braking the drive. If the times in the field “Smoothing“ are set to “0”, this will result in linear ramps, otherwise movement will be a parabola-shaped speed function. If the setting “Total time“ equals “Smoothing”, the result will be a sinus-shaped acceleration curve.

8. Standard applications and settings of the parametrizing program

Positioning

In the field “Positioning” you can specify whether the destination is to be interpreted as absolute (related to the reference point) or relative. The option relative, related to last destination calculates the new position on the basis of the destination position currently reached or to be reached. The option relative is the current actual position. If current positioning is not yet completed, the two options will produce different results.

Start with current positioning

The field “Start“ with current positioning specifies the behaviour of the servo controller when positioning is still taking place and the starting command for a new destination is received. The following options exist:

- Wait for the end: current positioning is completed and the new positioning started (this can already be transmitted).
- Interrupt positioning: current positioning is interrupted and movement is made to the new position.
- Ignore starting command: the positioning task for the new position is not accepted until the current destination is reached.

Instant pre-control

The field “Instant pre-control” enables increased dynamics with the positioning procedures. The variable must be ascertained by experiment, as default value it should be set to 0.



Please note

A rebound switch at the digital starting input can lead to problems, if “Wait for the end“ or “Interrupt positioning“ are permitted during relative positioning. The drive may move a little too far.

8. Standard applications and settings of the parametrizing program

Checkbox synchronized Checkbox synchronized is required e.g. for the application “Flying saw.” Normally the checkbox is not marked with a cross.

Messages In the field “Messages“ you can parametrize trigger messages which can be transmitted via a digital output. These trigger messages show the remaining path or the remaining time to the end of current positioning.



See also the chapter ‘Extended functions of the parametrizing program’, section ‘Parameters/Device parameters/Digital outputs’.

GO! With the “GO!” button you can start positionierung with the destination currently shown.

Copy With the “Copy” button you can copy all the settings for a destination to another destination. In the dialogue thus accessed you can specify both the source and the destination positions.

Moving to positions

The following possibilities exist for moving to positions:

- via digital inputs
- with the RS232 command (serial interface)
- via the field bus (optional)

8. Standard applications and settings of the parametrizing program

Positioning via digital inputs

The individual destinations can be selected via digital inputs. A rising edge at digital input DIN8 causes the destination to be accepted and starts the positioning movement.

Controllers in the SEC-AC family have 4 digital inputs (DIN0...DIN3) for selecting the destination.

SEC-AC controller family				
DIN3	DIN2	DIN1	DIN0	Destination no.
0	0	0	0	0
0	0	0	1	1
...
0	1	1	1	7
1	0	0	0	8
1	0	0	1	9
...
1	1	1	0	14
1	1	1	1	15

8. Standard applications and settings of the parametrizing program

Positioning with the RS232 (serial interface)

By means of the serial interface, movement can be made to all 16 positions, as well as to a temporary “RS-232 position” with controllers of the SEC-AC family.



Parameters/Positioning/
Goto destinations

The command structure can be found in the Appendix.

Movement to the 16 destination positions and reference travel can be triggered via the parametrizing program. To do this, activate the menu item [Parameters]/[Positioning]/[Goto destinations]. The following window will then appear:



Fig. 8/9

You can move to the relevant destination by clicking the appropriate button.

8. Standard applications and settings of the parametrizing program

8.4.3 Setting digital outputs

By setting digital outputs in positioning mode, you can inform a higher-order controller that positioning is/will be concluded.

1. Nominal position = destination position
2. Actual position = destination position
3. Remaining time to end of positioning procedure reached
4. Remaining path to end of positioning procedure reached
5. Reference travel active



Configuration of the digital outputs is described in the chapter 'Extended functions of the parametrizing program', section 'Parameters/ Device parameters/ Digital outputs'. Possibilities 3 and 4 are described in more detail in the section "Setting positions" in this chapter.

Parameters/Positioning/
Messages

For possibility 2, you must define a tolerance window, in the limits of which the digital output is to be set. You can do this in menu item [Parameters]/ [Positioning]/[Messages]. The following window will appear:

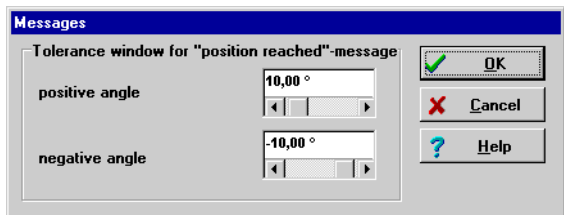

Fig. 8/10

Here you can set the tolerance window for the "Xactual = Xdestination" message.

8.5 Master-slave operation

In master-slave operation two servo controllers are coupled together. The master passes the position information onto the slave via the incremental sensor output (plug X11). The slave reads this information via the external incremental sensor input (plug X10). The plugs must be connected for this purpose with a 1:1 cable (pin 1 with pin 1, pin 2 with pin 2,). The diagram below shows the configuration.

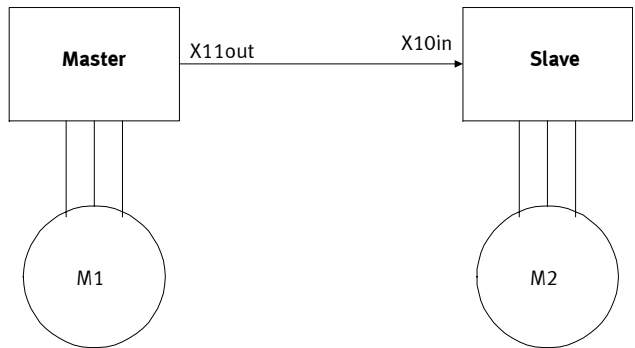

Fig. 8/11

The master operates in one of the previously described modes (speed control, positioning), while the slave operates in the synchronized mode.

The following operating modes are possible with this configuration:

- Speed-synchronous positioning
- Position-synchronous movement
- Electronic gears
- Special applications, e.g. “flying saw” (after consultation).

8. Standard applications and settings of the parametrizing program

8.5.1 Speed-synchronous positioning

Speed-control

In the speed-synchronous mode, the master specifies a certain speed to the slave. Movement must be made at this speed. The master is normally in the speed-control mode.



Please note

The position of the axes is not controlled in this case.

The diagram below shows a simplified control circuit for the slave.

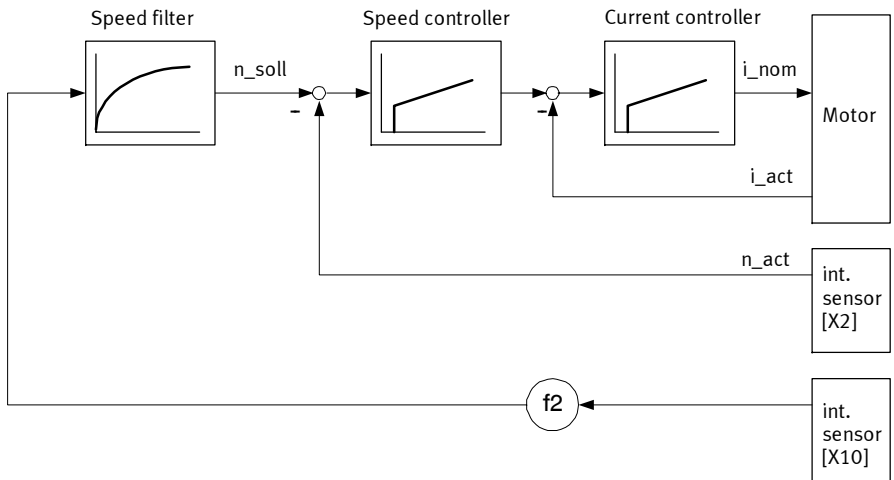

Fig. 8/12

As can be seen in the drawing, the speed specified by the master can contain a proportionality factor.

8. Standard applications and settings of the parametrizing program

In order to set speed-synchronous positioning, you must configure the slave as follows:

Command window	
Torque control	OFF
Speed control	ON
Setpoint ramp	Optional ^{*)}
Position control	OFF
Positioning module	ON
Synchronization	OFF
*) In most cases the setpoint ramp is switched off in this operating mode.	

Setpoint/Setpoint-selection

In the menu [Setpoint]/[Setpoint-selection] either “Selector A” or “Selector B” must be set to “Sync input”.

8. Standard applications and settings of the parametrizing program

Parameters/
Synchronization

The synchronizing menu must be configured correctly. It can be accessed with [Parameters]/[Synchronization]. The following window will then appear:

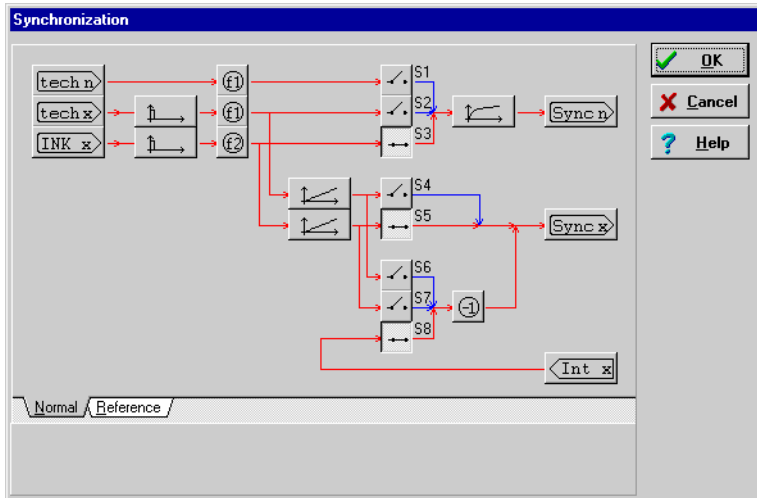

Fig. 8/13

The switches must be configured as follows:

Switch configuration	
S1	Open
S2	Open
S3	Closed
S4	Open
S5	Open
S6	Open
S7	Open

8. Standard applications and settings of the parametrizing program

INK_x

With a click on the “INK_x” button, you can set the bar code of the external incremental sensor.

f2

With the “f2” button, you can enter the proportionality factor for the speed specification (see also the control circuit diagram). The proportionality factor must be specified with counterand denominator.

The externally supplied speed can also be filtered. You can set the external speed filter by clicking the button shown below.



8. Standard applications and settings of the parametrizing program

8.5.2 Position-synchronous movement

Positioning

In the position-synchronous mode, the master specifies a certain position to the slave. Movement must be made to this position. The master is normally in the positioning mode.

The diagram below shows a simplified control circuit for the slave.

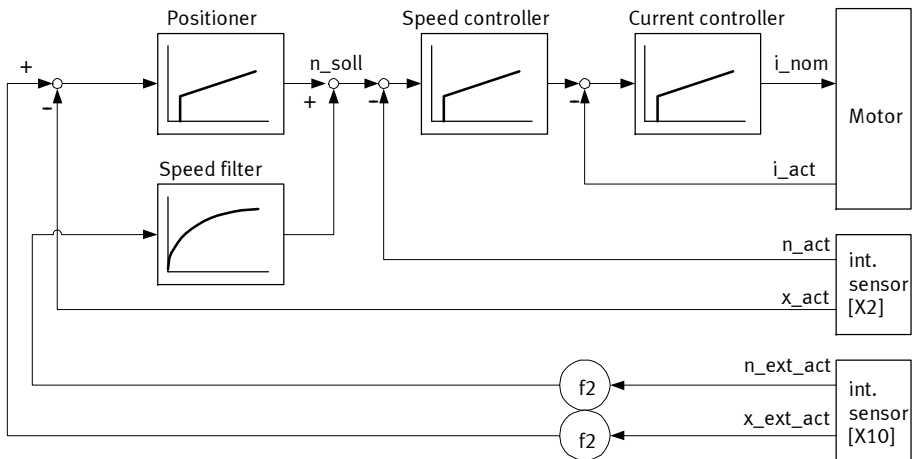

Fig. 8/14

The speed feedback from the external sensor is not absolutely necessary, but is to be recommended, as the positioning module would operate very slowly, due to its very high time constant.

As can be seen in the drawing, the position and speed specified by the master can contain a proportionality factor.

In order to set position-synchronous movement, you must configure the slave as follows:

8. Standard applications and settings of the parametrizing program

Command window	
Torque control	OFF
Speed control	ON
Setpoint ramp	OFF
Position control	ON
Positioning module	OFF
Synchronization	ON

Setpoint/
Setpoint-selection

In the menu [Setpoint]/[Setpoint-selection] either “Selector A” or “Selector B” must be set to “Sync input”.

Parameters/
Synchronizing

The synchronizing menu must be configured correctly. It can be accessed with [Parameters]/[Synchronizing]. The following window will then appear:

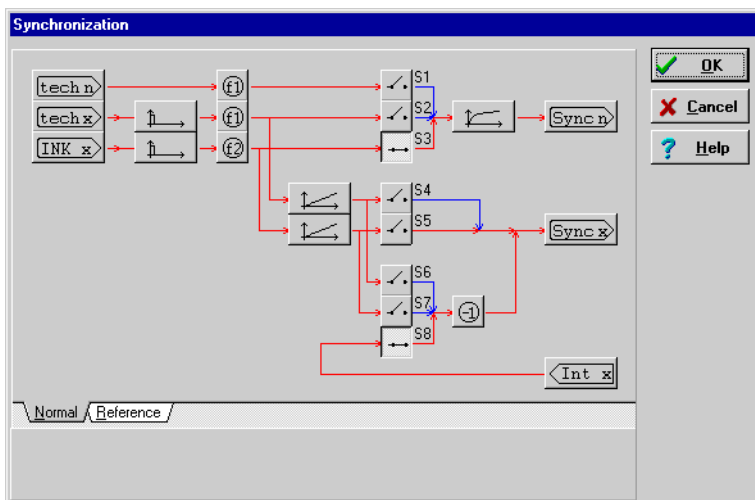

Fig. 8/15

8. Standard applications and settings of the parametrizing program

The switches must be configured as follows:

Switch configuration	
S1	Open
S2	Open
S3	Closed ^{*)}
S4	Open
S5	Closed
S6	Open
S7	Open
S8	Closed
*) recommended	

INK_x

With a click on the “INK_x” button, you can set the bar code of the external incremental sensor.

f2

With the “f2” button, you can enter the proportionality factor for the speed specification (see also the control circuit diagram). The proportionality factor must be specified with counter and denominator.

The externally fed speed can also be filtered. You can set the external speed filter by clicking the button shown below.



Further application possibilities (e.g. combination of positioning and synchronizing) on request.

8. Standard applications and settings of the parametrizing program

8.6 Timing the digital signals

8.6.1 Digital inputs

At the beginning the program undergoes basic parametrizing. This is followed by Controller enable with ENA-PWR (Enable-Power) and ENA-Cl (Enable-Controller). The digital inputs used are described in the table below.

Input/output	Value	Function
Din0 - Din3	Pos-Bit0 - Pos-Bit3	Destination selection
Din4	ENA_PWR	Input for final stage enable
Din5	ENA_Cl	Input for controller enable
Din6 - Din7	END-0 - END-1	Limit switch
Din8	START	Start positioning in positioning mode
Din9	SAMPLE	Input for additional reference switch

Fig. 8/16

8. Standard applications and settings of the parametrizing program

8.6.2 Timing the final stage enable and controller enable

The time relationships are described in the graph and table below.

Parameter		Delay time			Unit
T	Description	Min	Typical	Max	
t1	Gap between rising edges	0	–	–	ms
t2	Delay after controller enable on	2	7	14	ms
t3*)	Delay after controller enable off	tFast stop/at least 100	tStop	–	ms
t4	Delay after final stage enable off. The motor coasts	2	–	15	ms
t5	Minimum duration controller enable off	15	–	–	ms
t6	Minimum duration controller enable off	15	–	–	ms

*) tFast stop: applies to setpoint specification,parametrizing

Fig. 8/17

For calculating the braking time during speed regulation or tStop: The following formula applies for the positioning mode without controller enable:

$$t_{\text{Stop}} = (\max(v_{\text{max}}/a_{\text{max}}, 100\text{ms}) + t_{\text{filt}}) \cdot v_{\text{nominal}}/v_{\text{max}}$$

The larger of the two values, either 100 ms or $v_{\text{max}}/a_{\text{max}}$, is added to the actual speed value filter constant and then multiplied by the ratio of the nominal speed value v_{nominal} and the maximum speed v_{max} .

Maximum braking delay: a_{max} (parametrizing is made via the CAN object “6510” Subindex “15”).

8. Standard applications and settings of the parametrizing program

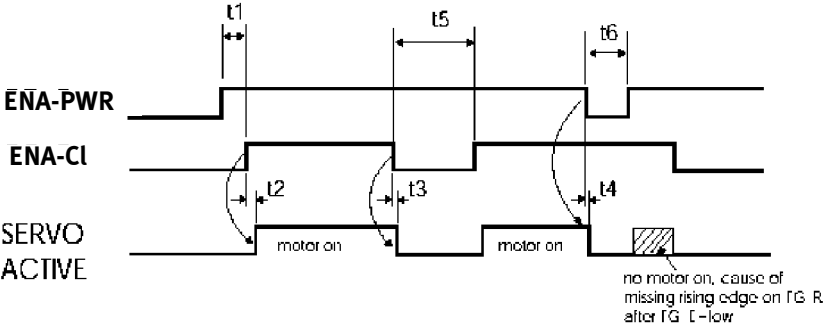

Fig. 8/18 Timing the final stage and controller enable: After ENA-PWR at high, a rising edge is required At ENA-CL

8. Standard applications and settings of the parametrizing program

8.6.3 Timing the limit switches

The limit switches serve for limiting the positioning path of an axis. If a limit switch is actuated, a so-called 'quick stop' will follow. This means that the axis is brought to nominal speed value "0" at maximum acceleration.

Parameter	Description	Delay time			Unit
		Min	Typical	Max	
t7	Delay after actuation of limit switch	100	t _{Stop}	–	ms
t8	Delay after limit switch enable	100	t _{Stop}	–	ms

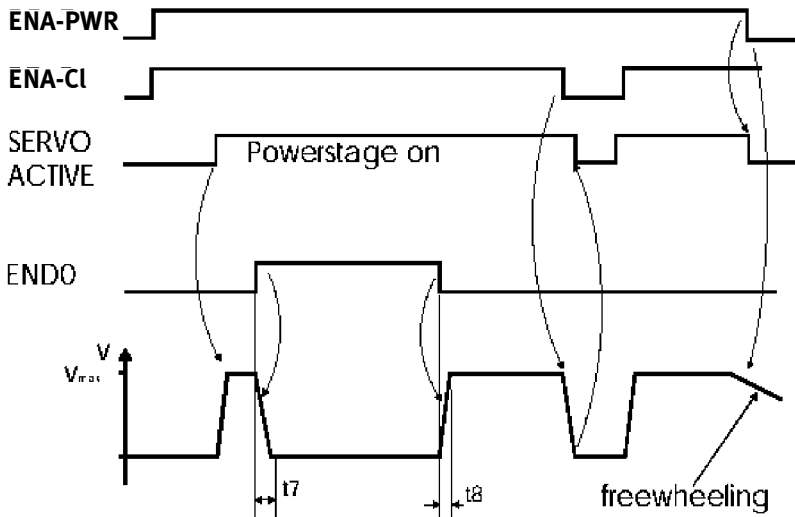

Fig. 8/19 Timing the limit switches

8. Standard applications and settings of the parametrizing program

8.6.4 Timing the control signals for the positioning module

You can carry out positioning by creating a bit combination with “Din0-Din3” and then enabling the positioning with “Din8” (START). The positioning controller has three modes for transferring the position Data record.

8. Standard applications and settings of the parametrizing program

Positioning after current positioning

A feature of this parametrizing is that new positioning cannot be loaded or actuated before previous positioning is completed.

Parameter		Delay time			Unit
T	Description	Min	Typical	Max	
t9	Duration of start signal	13	–	–	ms
t10	Position selection until actuation by Start ^{*)}	13	–	–	ms
t11	Duration of actuation after start high	13	–	–	ms
t12	New start after positioning completed	13	–	–	ms

^{*)} Positioning control is parametrized to "IGNORE START COMMAND"

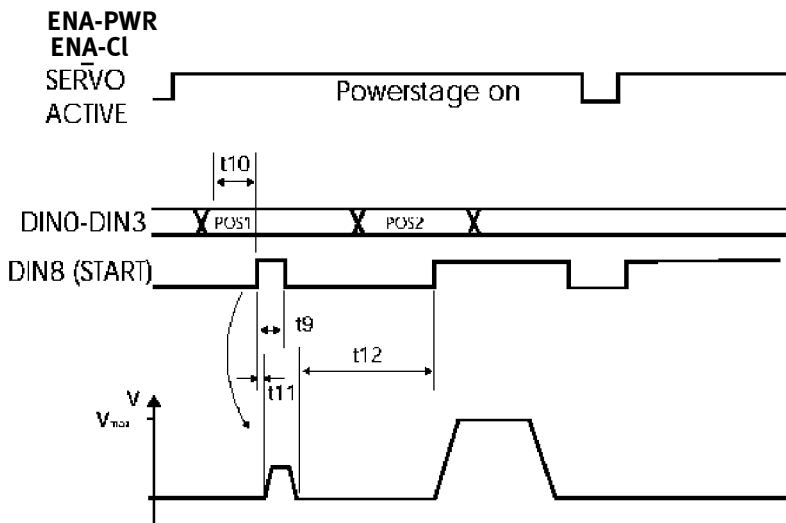

Fig. 8/20 Positioning by position selection and starting new positioning when previous positioning is completed: The new position cannot be preloaded by Start

8. Standard applications and settings of the parametrizing program

New positioning during current positioning

A feature of this parametrizing is that new positioning can be loaded and actuated before previous positioning is completed. The positioning thus loaded and actuated will be started automatically when previous positioning is completed.

Parameter		Delay time			Unit
T	Description	Min	Typical	Max	
t13	Delay of start after Din0-Din3 ready ^{*)}	13	–	–	ms
t14	Duration of start signal ^{*)}	13	–	–	ms
t15	Create new position after start low ^{*)}	13	–	–	ms

^{*)} Positioning control is parametrized to "WAIT FOR END"

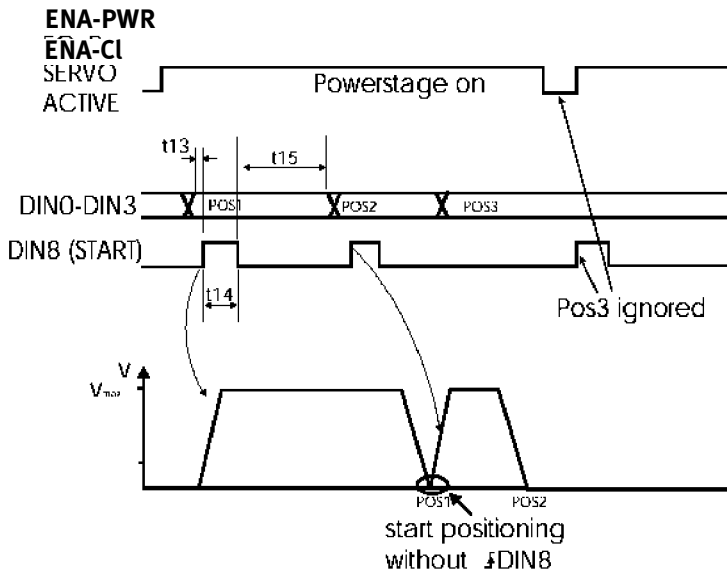

Fig. 8/21 Positioning by position selection and starting new positioning if previous positioning is not completed. The new position can be loaded with Start.

8. Standard applications and settings of the parametrizing program

New positioning by interrupting current positioning

A feature of this parametrizing is that new positioning can be loaded and actuated before previous positioning is completed and current positioning can be interrupted.

Parameter T	Description	Delay time			Unit
		Min	Typical	Max	
t16	Delay of start after Din0-Din3 ready	13	–	–	ms
t17	Create new position after start low ^{*)}	13	–	–	ms
t18	Duration of the start signal ^{*)}				

^{*)} Positioning control is parametrized to "INTERRUPT THIS"

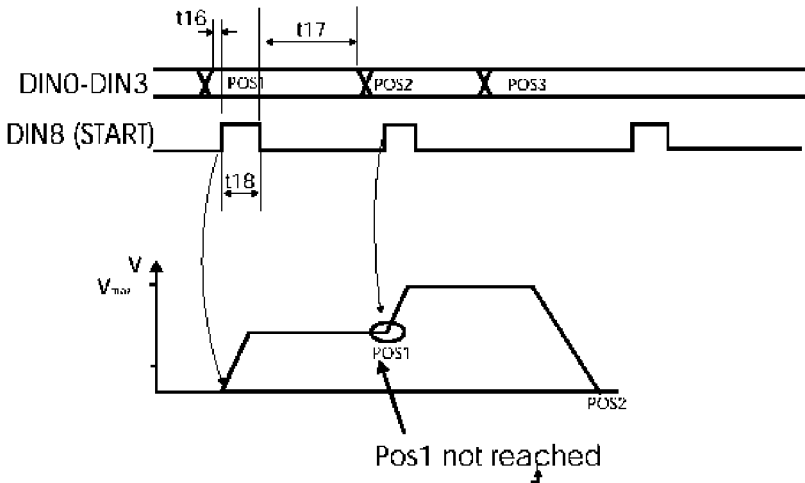

Fig. 8/22 Positioning by position selection and starting new positioning by interrupting current positioning.

8. Standard applications and settings of the parametrizing program

8.6.5 Feedback messages from the servo controller

Positioning ready messages (Xnominal=Xdestination, Xactual=Xdestination)

For feeding back the status to higher-order controllers during the processing of positioning profiles, you can use signals which can be parametrized as desired on one of the 3 digital outputs ([Parameters]/[Device Parameters]/[Digital Outputs]).

- “Xnominal=Xdestination” comes when the positioning profile of the positioning control has been processed. This signal can be used for switching further the positioning data records.
- “Xactual=Xdestination” is configured via the tolerance window ([Parameters]/[Positioning]/[Messages]). This signal comes when the position lies within the tolerance window. It can also trigger when a load moves the motor shaft out of its position.

8. Standard applications and settings of the parametrizing program

Parameter		Delay time			Unit
T	Description	Min	Typical	Max	
t19	Delay after start high	2	–	13	ms
t20	Minimum impulse duration*)	13	–	–	ms
t21	Delay after positioning ready	2	–	13	

*) With a very small tolerance window or large load disturbances

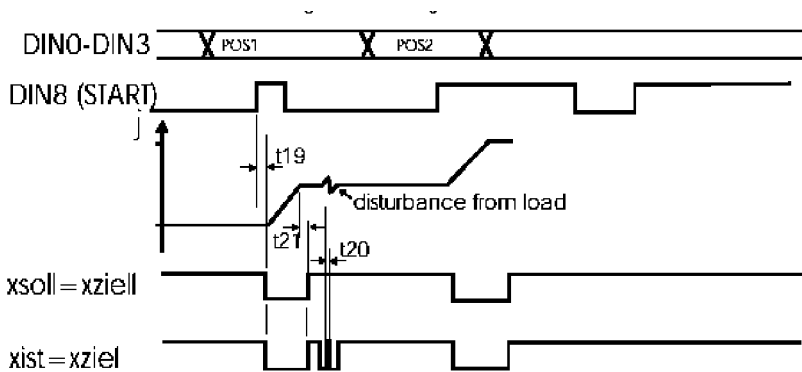

Fig. 8/23 Fig. 11/19 Ready messages “Xnominal=Xdestination” and “Xactual=Xdestination” after positioning.

Rest time and rest path messages

In addition to the ready messages, which cannot be parametrized separately for each positioning data record, there are two parameters for displaying the path still to be traversed and the time still required ([Parameters]/[Positioning]/[Destination Parameters]).

If the condition is fulfilled, the relevant outputs will switch to high level.

([Parameters]/[Device Parameters]/[Digital Outputs]).

- “Rest path” comes when the positioning profile of the positioning controller still has to traverse the stretch entered in the rest path.
- “Rest time” comes when the positioning profile of the positioning controller still requires the time entered in the rest time. This signal can also be used for further switching the positioning data records.

8. Standard applications and settings of the parametrizing program

Parameter		Delay time			Unit
T	Description	Min	Typical	Max	
t22	Delay after start high Rest path LOW after start*) **) Rest time LOW after start *)	2	–	13	ms
t23		2	–	–	ms
t24		2	–	100	ms

*) With a long rest path (rest path longer than positioning length) the rest path display remains constantly active.
 **) The calculations refer to the setpoints from the positioning controller, not to the actual values measured. If the measurements cannot follow the positioning profiles specified by the positioning controller, deviations may occur.

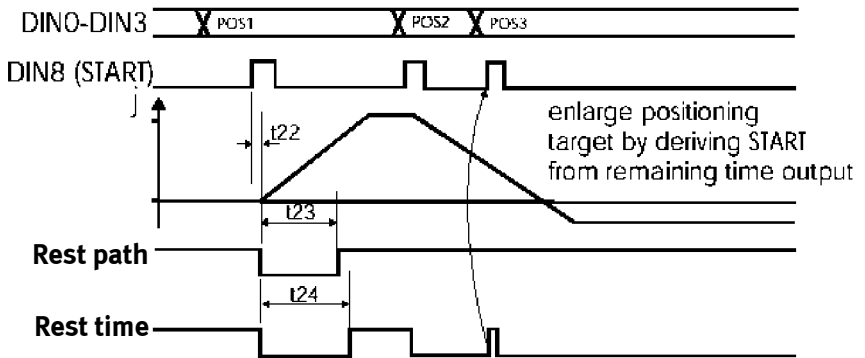

Fig. 8/24 Rest path and rest time messages during positioning.

Extended functions of the parametrizing program

Chapter 9

9. Extended functions of the parametrizing program

9.	Extended functions of the parametrizing program	9-1
9.1	File/Transfer window	9-3
9.2	File/Installation device files	9-4
9.3	File/Concluding the program	9-4
9.4	Setpoints/Setpoint specification	9-5
9.5	Analogue monitor	9-7
9.6	Parameters/Device parameters/Setpoint scaling	9-8
9.7	Parameters/Device parameters/Setpoint integrator ramp	9-9
9.8	Parameters/Device parameters/Speed message	9-12
9.9	Parameters/Device parameters/Digital outputs	9-13
9.10	Parameters/Device parameters/Intermediate circuit voltage	9-14
9.11	Parameters/Device parameters/Automatic brake	9-15
9.12	Error window	9-17
9.13	Options/German - English	9-19
9.14	Options/User mode	9-19
9.15	Options/Window for RS232 transmission	9-20
9.16	Options/Torque in Nm	9-21
9.17	Options/Oscilloscope	9-21
9.17.1	Register card "Channel representation"	9-22
9.17.2	Register card "Trigger"	9-23
9.17.3	Register card "Generator"	9-26
9.17.4	Register card "Controller"	9-27
9.17.5	Lower status bar	9-28
9.18	Help/Using help	9-30
9.19	Help/Themes	9-30
9.20	Helps/Information	9-31
9.21	Fast access via the icon bar	9-32

9.1 File/Transfer window



The “Transfer“ window is only accessible in the “Expert“ mode. For switching on the Expert mode see the chapter “Setting the basic settings/mode of the parametrizing program”.

The parametrizing program communicates with the servo controller via the serial interface. A certain protocol, in which the individual commands are determined, is used for this purpose. The “Transfer” window enables you to send the commands directly to the servo controller and to observe the reply.

File/Transfer

You can activate the transfer window with the menu command [File][Transfer]...



Please note

While the “Transfer” window is active, other open windows are not operated (e.g. Actual values, Oscilloscope). Close the “Transfer” window if you no longer require it.

The “Transfer” window serves for commands which are of no interest for normal operation. Furthermore, memory locations can be read and written. This, too, is only necessary in special cases.

9. Extended functions of the parametrizing program

9.2 File/Installation device files



Festo has the possibility of sending additional information by diskette or E-mail. This information can be:

- motor selection list (not yet implemented)
- special parametrizings
- if necessary, special firmware (notyet implemented)

File/
Installation device files

In order to incorporate the additional information in the parametrizing program, select the menu item [File]/[Installation of device files].



The actual installation is carried out exactly as already described in the chapter 'Installation', first program start and communication, sub-chapter 'Installation'.

9.3 File/Concluding the program

You can conclude the program as follows:

- by selecting menu item [File]/[Exit]
- by the key combination ALT+F4
- by the key combination ALT+X
- by clicking the cross at the top left of the main window.

9. Extended functions of the parametrizing program

9.4 Setpoints/Setpoint specification

RS232

In order to specify a setpoint via the parametrizing program, one of the two setpoint-selectors must be set to “RS232” (=serial interface). (See previous chapter). This is usually setpoint-selector A. With the setpoint specification you can specify speeds (in speed-control mode) or torques (in torque-control mode).

Setpoints/Setpoint specification

In order to specify the setpoint via the parametrizing program, activate menu item [Setpoints]/[Setpoint specification]. The following window will appear:



Fig. 9/1

9. Extended functions of the parametrizing program

You can enter setpoints:

- by entering a value in the entry line and by pressing ENTER
- by actuating the slide controller.

STOP

In order to transfer setpoint 0 (emergency stop function), click the “STOP” icon.

Transfer

In order to implement setpoint jumps, you must delete the tick in the checkbox “Transfer immediately” by clicking it. The new setpoint will not be transferred until you click the “Transfer” button.

9.5 Analogue monitor

The servo controller possesses two analogue outputs for displaying control variables. These can be represented with an external oscilloscope or they can also be used as processing signals.

Analogue monitor

In order to configure the analogue monitor, you must select the menu item [Analogue monitor], and the appropriate channel as sub-menu.

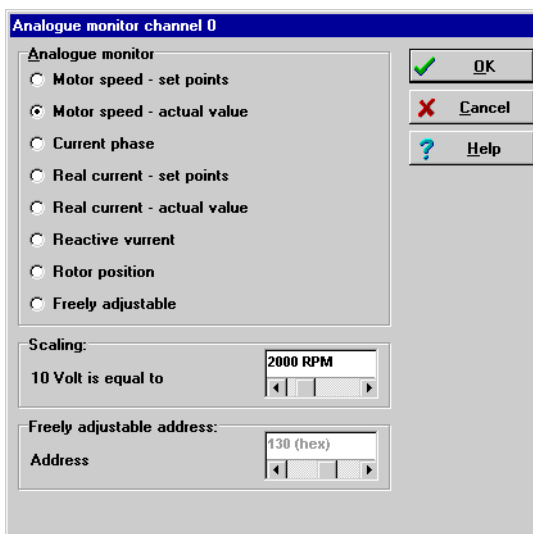

Fig. 9/2

Select the appropriate variable which is to be output by the analogue monitor.

Freely set address

The option “Freely adjustable address” is reserved for special applications.

9. Extended functions of the parametrizing program

9.6 Parameters/Device parameters/Setpoint scaling

The servo controller can process analogue setpoint specifications in both torque-control and speed-control modes. (See also the chapter 'Setpoints/Setpoint-selectors'). The controller has two analogue inputs for this purpose. With this menu you can assign an input voltage to a setpoint (speed or torque).

Parameters/
Device parameters/
Setpoint scaling

You can activate the menu with: [Parameters]/[Device parameters]/[Setpoint scaling]. The following window will appear:

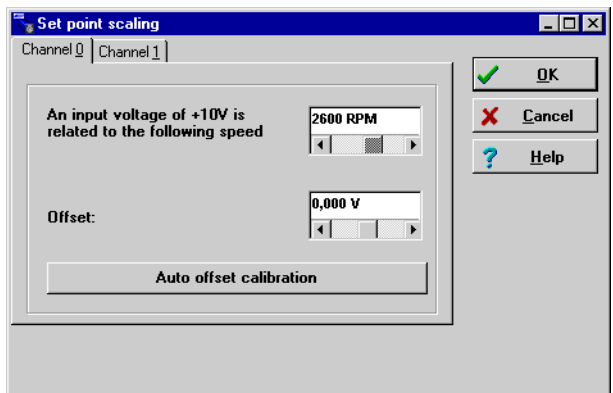

Fig. 9/3

The 'conversion factor' between the input voltage and the setpoint is specified with the upper value. The lower value is the zero point reference of the setpoint.

9. Extended functions of the parametrizing program

Automatic offset comparison

There is usually the problem that only a very small setpoint can be generated with an externally specified voltage of "0 V". The offset must be adapted here by a certain amount of millivolts. You can do this manually by setting the offset value accordingly. However, we recommend that you carry out an automatic offset comparison. To do this, you must click the "Auto offset calibration" button.

9.7 Parameters/Device parameters/Setpoint integrator ramp

The servo controller can process setpoint jumps in different ways. It can pass the jump onto the torque controller or speed controller unfiltered, or it can calculate a function which will combine the different setpoints by means of a ramp with an adjustable gradient (setpoint integrator).



Setpoint ramp

The setpoint ramp is only available for setpoint-selector A.

The ramp function is available when the box "Setpoint ramp" in the "command" window is marked with a tick.

Parameters/Device parameters/SPI-ramp (Setpoint integrator)

The menu itself can be activated with [Parameters]/[Device parameters]/[SPI-ramp]. The following window will then appear:

9. Extended functions of the parametrizing program

The screenshot shows a dialog box titled "SPI-ramp" with a blue header bar. It contains several sections for configuring ramp times:

- Connections:** Three checkboxes are present: t1 = t3, t2 = t4, and t1 = t2 = t3 = t4.
- Turn right:** Two ramp time settings: t1: 0 to 6000 RPM (0,426 s) and t2: 6000 to 0 RPM (0,426 s).
- Turn left:** Two ramp time settings: t3: 0 to -6000 RPM (0,000 s) and t4: -6000 to 0 RPM (5,971 s).
- Quick stop:** One ramp time setting: t5: 6000 to 0 RPM (0,200 s).

On the right side, there are three buttons: "OK" (with a green checkmark), "Cancel" (with a red X), and "Help" (with a blue question mark). At the bottom, an attention message reads: "Attention: The times will only be altered after the regulator has been enabled once!"

Fig. 9/4

The ramps can be set separately for clockwise and anti-clockwise running, also for rising and falling speeds/torques. If the ramp times are almost the same, the entry procedure can be shortened if the checkboxes ($t1=t3$; $t2=t4$; $t1=t2=t3=t4$) are used.

9. Extended functions of the parametrizing program

Fast stop

Controller behaviour in certain cases

In the following cases the positioning process is stopped and the drive is stopped in quick stop mode:

- if a limit switch is triggered during a positioning movement
- if the controller disable is activated during the movement (e.g. emergency stop).

Controller enable is not deactivated here in order to permit controlled braking of the drive.

In the fast stop mode the drive is braked either with maximum braking force or with a defined braking ramp. To do this you must set the entry “Quick stop” in the menu [Parameters]/[setpoint scaling] to a value greater than “0”. This value corresponds to the braking time for the quick stop. The greater this time, the more slowly the motor will be braked.

When the device comes to a stand in the latter case, the controller disable becomes active. The device is then without power.



Please note

The quick stop setting is necessary in order to limit the mechanical stress on the axes coupled to the motor to within the permitted tolerances. If the quick stop time is too brief, the drive system may be damaged in the event of a quick stop being triggered.

The “quick stop” ramp should be set so that neither the axis nor the motor are damaged in an emergency stop. In practice, a time value is used corresponding to a delay of 10 m/s.



Please note

The times set do not become effective until there is a new controller enable.

9.8 Parameters/Device parameters/Speed message

For monitoring the speed, there is a device in the servo controller which sets a bit in the status word when the current motor speed is in a parametrizable speed range. The speed message can be parametrized in this window.

The menu can be activated with [Parameters]/[Device parameters]/[Motor speed message]. The following window will then appear:

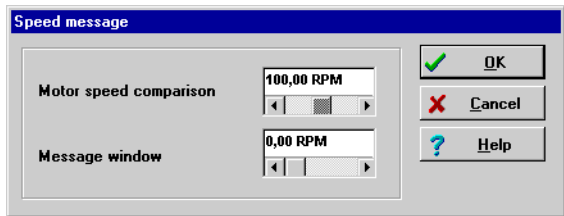

Fig. 9/5

In the field “Motor speed comparison“ you can specify the speed at which the speed message is to be triggered.

In the field “Message window” you can specify a hysteresis. The speed may exceed or be lower than the parametrized value here, up to a maximum value, in order that the speed message can still be triggered.

If the hysteresis is too small, it will cause a wobbling output signal.

The status of the bit for the speed message can be shown on a digital output, if this is configured accordingly. See also the following chapter.

9.9 Parameters/Device parameters/Digital outputs

The servo controller possesses a total of five digital outputs. Three of these outputs can be freely configured. i.e. various status messages from the controller can be placed on these outputs and information thereby sent to a higher-order controller. Digital output 0 cannot be parametrized, it is used for displaying the readiness to operate. This signal is also shown by the LED on the front of the servo controller.

If your motor has a parking brake and if this is to be switched via a digital output, then a special output is available which must not be parametrized.

The menu can be activated with [Parameters]/[Device parameters]/[Digital outputs]. The following window will then appear:

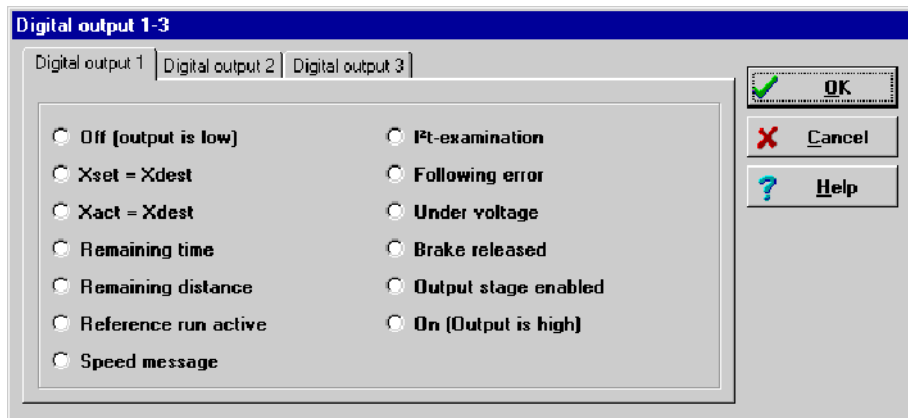

Fig. 9/6

All status messages which can be shown on the digital outputs can be set in the appropriate menu of the parametrizing program. With the settings “On (output is high)” and “Off (output is low)” you can assign a certain value to the output.

9.10 Parameters/Device parameters/Intermediate circuit voltage

In special applications, it may happen that the intermediate circuit voltage is either too high or too low.

If the intermediate circuit voltage is too high (overvoltage), an integrated brake chopper will switch in a parallel resistor, so that the voltage can be reduced via this brake resistor. This brake resistor is incorporated in the SEC-AC. If the voltage rises again, the controller will switch itself off. This function cannot be parametrized.

If the intermediate circuit voltage has been parametrized too low by the user, faults may be triggered. The menu can be activated with [Parameters]/ [Device parameters]/[Intermediate circuit control]. The following window will appear:

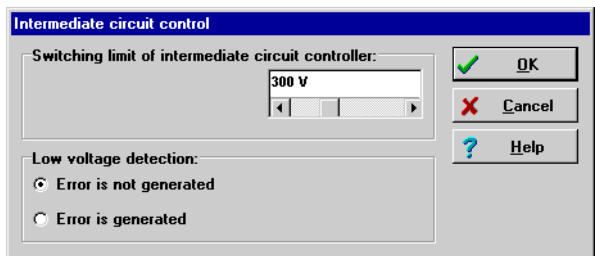

Fig. 9/7

Response threshold

In the field “Response threshold“ you can specify the value under which the voltage must sink, in order that the controller can recognize an undervoltage.

Parameters/Device parameters/Digital outputs

The flag, which is set in the controller, can be read by various status interrogations, e.g. a digital output can be parametrized so that it displays the event “Undervoltage in the intermediate circuit”. (See also the section ‘Parameters/ Device parameters/Digital outputs’).

9. Extended functions of the parametrizing program

Error signal

In the field “Error signal,” you can specify whether an error message with controller switch-off is to be generated in the event of undervoltage.

9.11 Parameters/Device parameters/Automatic brake

If your motor has a parking brake, this can be supplied with power by the servo controller. The controller can only switch parking brakes which operate at a rated voltage of 24 V DC. In order to activate the parking brake, you must activate the menu [Parameters]/[Device parameters]/[Automatic brake]. The following window will appear:

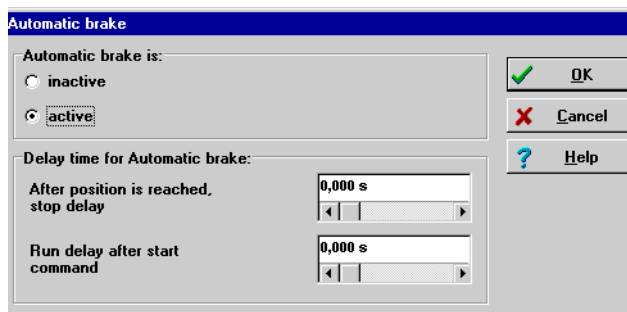

Fig. 9/8

A digital output is provided in the servo controller for switching the brake. The brake is always switched as soon as the controller enable is switched on. The servo controller also has an automatic brake, for which various times can be parametrized. These times are only effective when the automatic brake mode is activated.

9. Extended functions of the parametrizing program

You can parametrize a positioning start delay. In the speed-control mode, this delay time causes the brake to be switched and the nominal speed value to be maintained at zero for the parametrized time when the controller enable is switched on. In the positioning mode, this delay time causes positioning to be started with a delay after a new start command.

This delay time is necessary for compensating the mechanical inertia of the brake. If your axis is under load (e.g. a vertical axis), this time must be parametrized at all costs, as otherwise the motor cannot hold its position when the brake is applied/released.

In the field “Start delay”, you can parametrize a further time. If positioning is carried out in the position control mode and if the axis has reached its destination, the brake will be applied and the controller will be disabled after this delay time. However, the synchronizer control must be switched off. If new positioning is started during this delay time, the brake will remain unswitched.

This delay time is provided to enable you to switch off the final stage in the case of axes under load, if positioning does not take place for long periods.

9.12 Error window

The error window is a permanent window in the user interface of the parametrizing program. If there is no fault, the window will remain in minimized form (see drawing).



Fig. 9/9

The error window can be represented in its full size as a result of three events:

1. When the menu item [Error] in the user list is clicked.
2. When the "Error" field (second field from the left in the lower status bar) is clicked.
3. Automatically when a fault occurs.

As soon as a fault occurs, two changes take place in the user interface of the parametrizing program:

1. The error window becomes larger and is shown full-size.
2. The fault is shown in red in the lower bar.

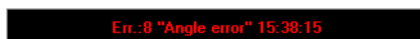
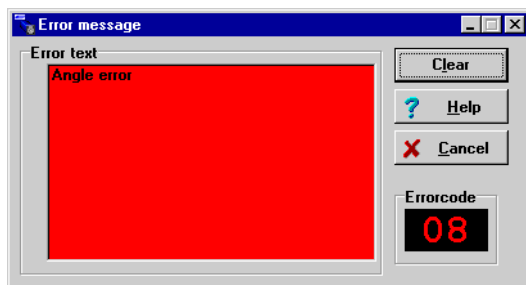

Fig. 9/10 Error messages

9. Extended functions of the parametrizing program

Error treatment takes place in three steps:

Help

1. **Fault analysis:** If the error text does not contain enough information and you would like to have further tips on how to rectify this fault, click “Help” in the error window. (In this example the fault has probably been caused by a broken/non-inserted connection to the phase-angle sensor).
2. **Fault remedy:** Rectify the cause of the fault. (In this example the phase-angle sensor must be connected correctly).

Delete

3. **Fault acknowledgement:** Click the “Delete“ button in the error window. If the fault can be rectified successfully, the window will be minimized again. If the fault still exists, the window will be shown full size again.

Abort

You can minimize the window by clicking the “Cancel” button. Any error messages which still exist will remain in the error window of the status bar.



The “Cancel” button does not rectify the fault.

9. Extended functions of the parametrizing program

9.13 Options/German - English

The language of the parametrizing program can be set with a click on the menu item [Options]/[Deutsch] or [Options]/[English].

9.14 Options/User mode



The setting of the user mode is described in the chapter 'Basic settings', section 'Setting the mode of the parametrizing program'.

9. Extended functions of the parametrizing program

9.15 Options/Window for RS232 transmission

When this menu item is accessed, a window is generated in which communication via the serial interface can be observed. This window serves mainly for debugging purposes and is not of interest for the “normal user”.

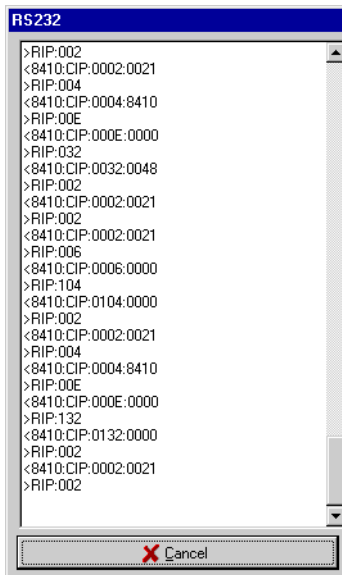

Fig. 9/11

9. Extended functions of the parametrizing program

9.16 Options/Torque in Nm



Information on this theme can be found in the chapter “Standard applications and settings of the parametrizing program”, section “Torque-control mode”.

9.17 Options/Oscilloscope

The oscilloscope function incorporated in the parametrizing program enables signal curves to be represented. It also permits the optimization of the current controller and the positioning module in reverse mode.

The oscilloscope can be activated with menu item [Options]/[Oscilloscope]. After an initialization phase, the following window will be shown:

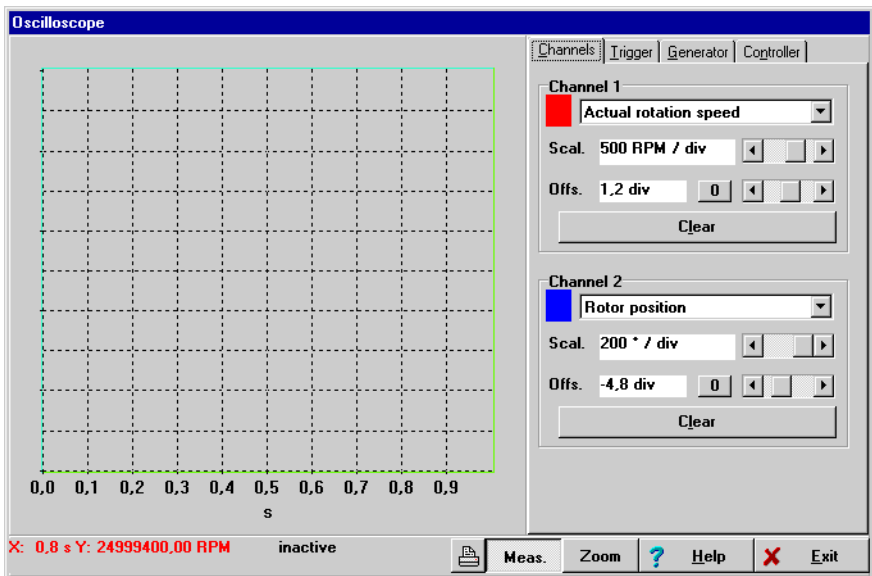

Fig. 9/12

9. Extended functions of the parametrizing program

In the right-hand half of the oscilloscope window there are four register cards for more exact settings:

- for selecting and representing the channels
- for setting the trigger
- for setting the reversing generator
- for setting the positioning module and the speed controller.

9.17.1 Register card “Channel representation”

The oscilloscope possesses two channels. The following settings can be made in the register card:

1. The measured variable to be represented: Click the selection box of the relevant channel.
 2. The colour of the channel: Click the coloured box. A dialogue for selecting the colour will be shown.
 3. Y-scaling: Use the slide switch next to “Scal”, in order to set the enlargement in the vertical direction.
 4. Offset / Y-position: Use the slide switch next to “Offs”, in order to shift the vertical position of the curve. A click on the box resets the offset to “0”.
- Scal
- Offs
- Clear
- You can delete the representation of the two curves by clicking the “Clear” button.

9.17.2 Register card “Trigger”

The trigger controls the recording process in the oscilloscope. Recording begins as soon as the “trigger event” occurs.

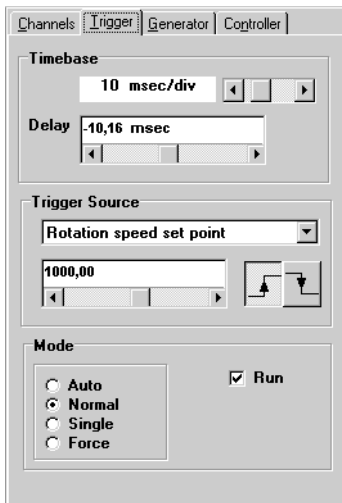

Fig. 9/13

Time base

1. You can specify the time resolution with the upper slide switch in the box “Timebase”. A value of 10 msec/div means that a box width in the oscilloscope representation corresponds to a time period of 10 milliseconds.

Delay

2. You can specify the position of the trigger event in the oscilloscope screen with the slide switch “Delay”. A delay value of “0” indicates that the trigger event is recorded at the left-hand edge of the oscilloscope screen. A negative delay value shifts the trigger event to the right.

9. Extended functions of the parametrizing program

3. The trigger source can be selected in the selection list in the box “Trigger source“ in the selection list. A distinction is made between digital and analogue trigger sources.
 - Digital trigger source: This can only assume the status Yes or No. An example is the controller enable.
 - Analogue trigger source: This assumes a numerical value. An example is the actual speed value.
4. Trigger threshold: Only visible with analogue trigger sources. The trigger process begins as soon as the analogue trigger exceeds or falls below the threshold.
5. Trigger edge: Use both the buttons in the box “Trigger source“. You can specify the moment of triggering. See the table below.



Rising edge	Falling edge
	
Digital trigger: event occurs Analogue trigger: threshold is exceeded	Digital trigger: event disappears Analogue trigger: threshold not reached

Fig. 9/14

9. Extended functions of the parametrizing program

6. Trigger mode: The moment of triggering can be set here. There are four different trigger modes:
- “Auto”: Triggering is carried out and displayed continuously, whether the triggering condition is fulfilled or not.
 - “Normal”: Triggering is carried out and displayed as soon as the triggering condition is fulfilled. Triggering continues after the display and when the triggering condition occurs again.
 - “Single”: Triggering is carried out only once when the triggering condition is fulfilled. The status is then switched inactive when the checkbox **Run** (see below) is deactivated.
 - “Force”: Triggering is carried out whether the triggering condition is fulfilled or not. The status is then switched inactive.



Please note

The trigger mode and the oscilloscope are only active when the checkbox “Run“ in the box “Mode“ is marked with a cross.

9.17.3 Register card “Generator”

In this menu you can set the reversing generator. This does not serve for normal operation, but simply for optimizing the speed controller and the positioning module. The reversing mode enables the controller to move backwards and forwards continuously between two positions.

The reversing generator is handled with low priority in the firmware. This can lead to delays in operation.

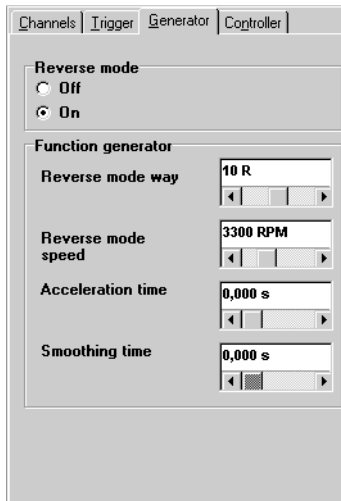

Fig. 9/15

The reversing mode can be switched on and off.



Caution

Before exiting the reversing mode, you must switch it off.

9. Extended functions of the parametrizing program

Reversing path/
Reversing speed

In the field “Reversing path“ you can determine the difference between the two positions. In the field “Reversing speed“ you can set the positioning speed.

Acceleration time

For normal cases, a square-wave function is required for the nominal speed. In this case, you must assign the field “Acceleration time“ with 0. If a ramp function is required, you must enter a value larger than 0.

The field “Smoothing time“ is only of interest when an acceleration time > 0 is specified. If the value of the field “Smoothing time“ is “0“, this will result in a linear acceleration ramp; otherwise a smoothing function will be used.

9.17.4 Register card “Controller”

In this menu you can test various settings of the current controller and positioning module. This should be carried out in the reversing mode.



The button “Restore“ will only be visible if you have modified the controller settings.



Notes on setting the speed controller can be found in the chapter ‘First start and optimizing the motor’, section ‘Optimizing the speed controller’.

9. Extended functions of the parametrizing program

9.17.5 Lower status bar

Measuring values

In order to ascertain the value of a measured variable, simply move the mouse to the appropriate point in the oscilloscope interface. In the lower status bar you will find information on the timing point and the value of the measured variable:



X: 6.3 ms Y: 0.00 UPM

Status of the oscilloscope

On the right next to the X/Y-display in the lower status bar you will find a field with information on the current status of the oscilloscope.



waiting for trigger

The most important messages are:

Message	Meaning
Inactive	Oscilloscope is switched off; the box "Run" in register card "Trigger" is not activated.
Waiting for trigger	Oscilloscope is activated and waits for the trigger event. The trigger event is not found.
Triggered	Trigger event is found; recording begins.
Reading	Read data are transferred to the parametrizing program by the servo controller.
OK	Recording is ready.

Fig. 9/16

9. Extended functions of the parametrizing program

Printing

The oscillogram can be printed out if the button shown below is pressed.



Representation mode

The oscilloscope possesses two representation modes: the Measuring mode and the Zoom mode. The mode currently active can be recognized in the lower status bar.



The standard mode is the measuring mode. You can switch from one mode to the other by clicking the appropriate button.

In the measuring mode, the XY-display is operated (see above). In the zoom mode, a part of the recorded curve can be enlarged. To do this, you must press down the left-hand mouse key and mark the field in the oscilloscope window which is to be enlarged. You can return to the original size by clicking the oscilloscope window with the right-hand mouse key.

9. Extended functions of the parametrizing program

9.18 Help/Using help

Under the menu item [Help]/[Help for help] you will find a general Windows help.

9.19 Help/Themes



See the chapter “Online helps”.

9. Extended functions of the parametrizing program

9.20 Helps/Information

Under the menu item [Helps]/[About] you will find the following window:

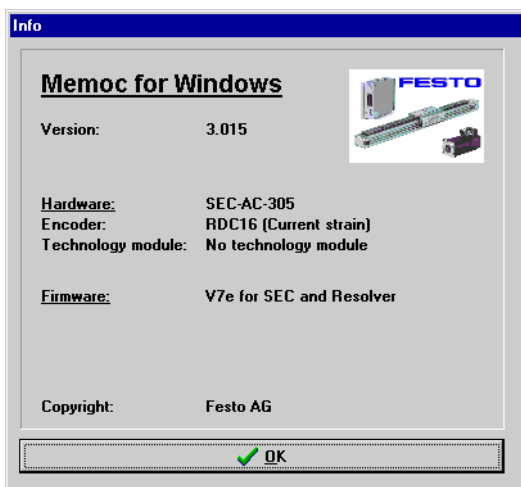

Fig. 9/17











The window contains the following information:

- the version number of the parametrizing software
- the device type of the servo controller
- the type of angle sensor used
- the type of technology module used (if available)
- firmware: version and specifications for angle sensors
- copyright note.

9. Extended functions of the parametrizing program

9.21 Fast access via the icon bar

Some of the functions of the parametrizing program can be accessed directly in the icon bar underneath the menu bar:

Symbols	Function
	Set German
	Set English
	Search for communication
	Online parametrizing
	Offline parametrizing
	Oscilloscope
	Motor data menu
	Current controller
	Speed controller
	Reference travel

9. Extended functions of the parametrizing program



Symbols	Function
	Set positions
	Move to positions

Fig. 9/18

9. Extended functions of the parametrizing program

Diagnosis and error treatment

Chapter 10

10. Diagnosis and error treatment

10.	Diagnosis and error treatment	10-1
10.1	Status display	10-3
10.2	General information	10-3
10.3	Outputting faults	10-4
10.4	Error list	10-5
10.5	Warning: old firmware	10-7

10. Diagnosis and error treatment

10.1 Status display

The following states are displayed by means of status messages:



Status	Description
	Controller enable
	Revolving outer segments – display of relative motor direction – display of relative motor speed

Fig. 10/1 Status list

10.2 General information

Extensive monitoring functions ensure very reliable operation of the servo controller. The micro controller and an additional external hardware logic register error signals from the motor, evaluate the shaft encoder and final output stage and can switch off the final output stage extremely quickly.

In addition to hardware faults, the servo controller can also recognize faults in the control circuit. This includes, e.g. faults in communication or in the positioning procedure.

10.3 Outputting faults

The user is informed of faults occurring in the servo controller in the following ways:

- by the display of a 2-figure error code number on the 7-segment display on the housing. First the tens figure of the error code number are shown, followed by the units figure. For example, error 08 will be indicated first by the display 0, then by the display 8 and finally a blank.
- If a PC with a parametrizing program is connected, the fault together with its error number will be shown in the error window and in the status bar. See also the chapter 'Extended functions of the parametrizing program', section "Error window".

10. Diagnosis and error treatment

10.4 Error list

Below is a table with error numbers, cause of fault and methods of rectifying the fault.

Error no.	Description	Remedy
02	Undervoltage in intermediate circuit	Check the 230 V AC power supply. See also chapter 'Extended functions of the parametrizing program', section 'Parameters/Device parameters/Intermediate circuit voltage'
03	Excessive temperature in motor	Check plug connection X6 and the connecting cable from the servo controller and the motor. If the motor does not have a temperature sensor, the relevant input on plug X6 must be short-circuited.
04	Excessive temperature in final stage	Check the fitting conditions of the servo controller. If necessary, a ventilator must be used.
05	Partial failure of low voltage supply	You cannot rectify this fault. Contact your Festo service.
06	Overcurrent/short circuit in final stage	Check the connecting cable to the motor. If you are using very long cables, this fault may be triggered by leakage currents. In this case, you must observe very closely the EMC safety instructions for the servo controller. The overcurrent fault may be caused by an incorrect current controller parametrization.
07	Overvoltage in the intermediate circuit	Check the 230 V AC power supply. See also chapter 'Extended functions of the parametrizing program', section 'Parameters/Device parameters/Intermediate circuit voltage'.
08	Angle sensor fault	Check plug X2 and the angle sensor cable from the servo controller and motor.
09	Path overrun when positioning	This fault occurs when the positioning range is overrun.
11	Fault in reference travel	This fault occurs when the maximum search path is exceeded. Either you must define a larger search path or the limit switch could not be found for other reasons. This fault also occurs when both limit switches are actuated at the same time.
14	Fault in angle sensor identification	Possible causes of fault: no intermediate circuit voltage, motor shaft cannot turn freely, rated current set too low

10. Diagnosis and error treatment

Error no.	Description	Remedy
16	Initialization fault	You cannot rectify this fault. Contact your Festo service.
17	Position deviation too large	This fault is shown when the value, which is set in the monitoring function as a drag fault, is exceeded. See chapter 'Extended functions of the parametrizing program', section 'Positioning module'.
18	Fault in positioning pre-calculation	You cannot rectify this fault. Contact your Festo service.
20	Incremental sensor input fault	Angle sensor wired incorrectly
21	Offset current measurement too large	Fault in current measurement. You cannot rectify this fault. Contact your Festo service.
25	Unknown device type	You cannot rectify this fault. Contact your Festo service.
26	Flash memory: no user parameter set	This fault only occurs if you switch off the servo controller within 3 seconds of issuing the command [Save parameter]/[parameter set] or if you press the reset button during this period. The data could not be written completely into the flash memory. You can rectify this fault by loading the parameter set again from the hard disc into the controller. See chapter "Basic settings", section "Loading preset parameter sets".
27	Flash memory: check sum fault	You cannot rectify this fault. Contact your Festo service.
28	Flash memory: write fault	You cannot rectify this fault. Contact your Festo service.
31	I ² t fault	

Fig. 10/2

10.5 Warning: old firmware

The parametrizing program possesses options which function at best with a firmware version as from 07e. If firmware of version V6 or older is found, the following warning will appear on the screen:

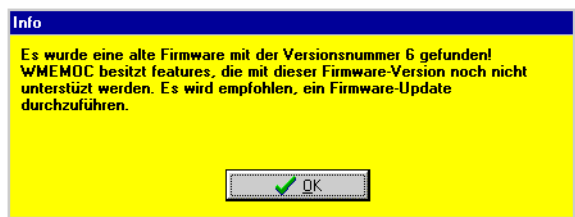

Fig. 10/3

Helps/About

You can find out the version of the current firmware by selecting [Helps]/[About] in the menu bar. You will then see the following menu:

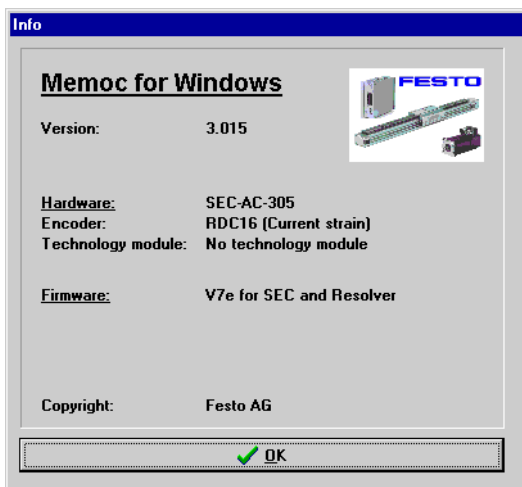

Fig. 10/4

10. Diagnosis and error treatment



(Firmware version V7d is loaded in this example.)

If the correct firmware is already loaded in the controller, you can omit this chapter.

Loading firmware into the servo controller

- | | |
|------------------------|---|
| File/Firmware download | 1. Select the command [File]/[Firmware download] in the menu bar. |
| Open | 2. Select the correct firmware for your servo controller from the file menu. See the table above. Then click “Open”. |
| 57600 baud | 3. You will be asked for the baud rate for the firmware download. Enter 57600 baud for the first attempt. This will guarantee a fast download. If there are problems with the download, select a lower speed and confirm with “OK”. |
| | 4. Follow further instructions. |

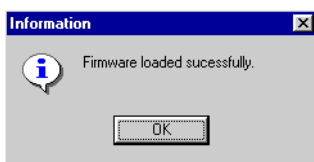

Fig. 10/5

A successful firmware download will be shown by the following message:

Fault in firmware download

If the firmware download is not successful, this will be shown by the message “Fault in firmware download”. The cause is usually a communication fault in transferring the data to the servo controller. Repeat the procedure described above with a lower baud rate.

List of the RS232 commands

Chapter 11

11. List of the RS232 commands

11.	List of the RS232 commands	11-1
11.1		11-3
11.2	General commands/messages	11-5
11.3	Selecting the operating mode	11-6
11.4	Specifying the speed	11-6
11.5	Reference travel/Position control	11-7
11.6	Synchronization unit	11-10
11.7	Parking brake	11-10
11.8	Commissioning/Calibrating	11-11
11.9	Parameter commands	11-11
11.10	Example of parametrizing	11-12

11. List of the RS232 commands

11.1 RS232 test possibilities



Caution

Due to direct operation of the SEC-AC via RS232 commands, there is full access to the internal variables of the servo controller. Incorrect operation can lead to unexpected reactions of the controller and the motor can start uncontrolled. Operation via the RS232 commands should therefore be undertaken only by experienced users.

The RS232 commands listed can be transmitted to the SEC-AC with any commercially-available terminal program. A simple terminal window has been included in the Wmemoc software for test purposes. The following window appears when you access the function under [File]/[Transfer]:

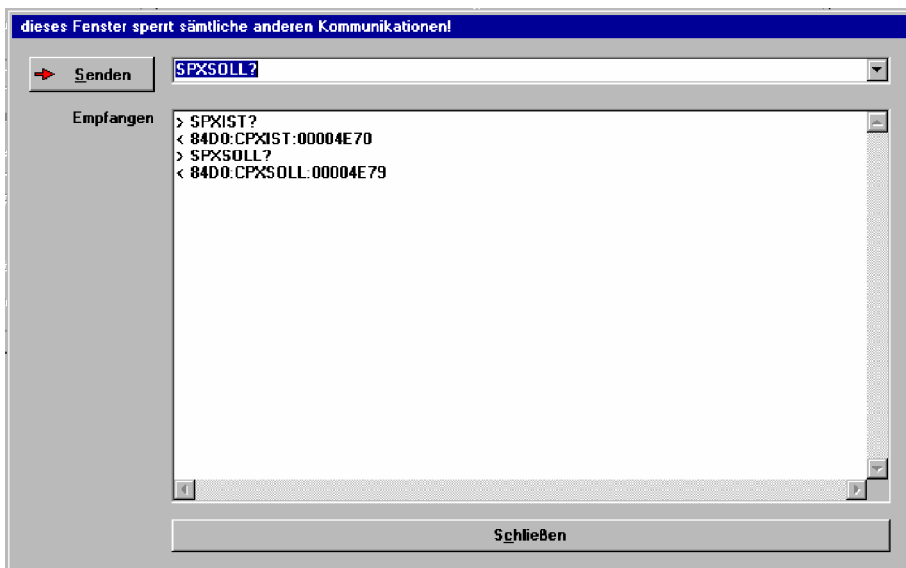

Fig. 11/1

11. List of the RS232 commands

Enter the command code in the upper line and confirm the transfer with the “Send” button.

The transferred command and the reply from the SEC-AC appear in the lower window.



Please note

When the “Transfer” window (Terminal window) is activated, all other communication protocols will be deactivated. The controller can then only be operated via this window until the “Transfer” window is deactivated.

The commands listed are implemented in the controllers as from firmware version 5c. Please contact Festo if you require an update.

11. List of the RS232 commands

11.2 General commands/messages

Command	Syntax	Reply
Controller enable on/off functions only when controller enable logic is set to Din5 and RS232	SRF+ / SRF-	xxxx:CRF+ / CRF-
Switches off the final stage	SES-	xxxx:CES-
Quits fault	SQT+ / SQT-	xxxx:CQT+ / CQT-
Re-initializes controller	RESET!	
Saves the parameters of the internal RAM in the external flash IC	SAVE!	DONE Programming_error! Verify_error!
Sets the baud rate for serial communication	BAUD9600 BAUD19200 BAUD38400 BAUD57600	xxxx:ok
Reads controller type	TYP?	
Command unknown		xxxx:ERR!
Buffer overrun		xxxx:OVL!

Fig. 11/1

11. List of the RS232 commands

11.3 Selecting the operating mode

Command	Syntax	Reply
Torque control mode on/off	SIN+ / SIN-	xxxx:CIN+ / CIN-
Switches positioning module on/off	SLA+ /SLA-	xxxx:CLA+ / CLA-
Position control on/off	SPO+ / SPO-	xxxx:CPO+ / CPO-
Switches synchronous run on/off	SYNC+ / SYNC-	xxxx:CSYNC+ / CSYNC-
Nominal value integrator on/off	SHL+ / SHL-	xxxx:CHL+ / CHL-

Fig. 11/2

11.4 Specifying the speed

For specifying the speed via the RS232, one of the nominal value selectors (A or B) must first be set to RS232 in the menu “Nominal values” with the parametrizing program.

Command	Syntax	Reply
Speed specification in rpm	SN4:HHHH	Xxxx:CN4:HHHH

Fig. 11/3

11.5 Reference travel/Position control

The following abbreviations apply to the positioning commands:

- PP: Positioning record (hexadecimal form)
- 00: CAN
- 01: Serial interface
- 02: Reference (not permitted)
- 03: POS 0
-
- 09: POS 6
- 0A: POS 7
- 12: POS 15
- TTTT: Time in ms (hexadecimal form)
- VVVV: Speed in rpm (hexadecimal form)
- XXXXXXXX: Path in increments (hexadecimal form)
(65536 increments are 1 revolution)
- MMMM: Each functionality corresponds to 1 bit.
The individual expressions must be OR-linked to form the total functionality.

11. List of the RS232 commands

Behaviour when start is made with current positioning

- 0000 Start is ignored with current positioning
- 0001 Current positioning interrupted (start)
- 0020 Wait for end of current positioning

Reference point for positioning:

- 0000 Current nominal position (relative positioning)
- 0002 Zero position (absolute positioning)
- 0010 Last (or not reached) destination

Synchronization:

- 0000 Synchronization off
- 0008 Synchronization on (for flying saw)

SS: Status after SPSTART/after SPSELPOS

- 00 Positioning started or controller ready for pos.
- 01 Positioning control is off
- 02 Final output stage is off
- 04 Reference travel active
- 08 Current positioning cannot be aborted

11. List of the RS232 commands

Command	Syntax	Reply
Starts reference travel	REFGO!	Xxxx:CREFGO
Set destination position	SPX:PP:XXXXXXXX	Xxxx:CPX:PP:XXXXXXXX
Set acceleration time	SPT1:PP:TTTT	Xxxx:CPT1:PP:TTTT
Set smooth part	SPT1R:PP:TTTT	Xxxx:CPT1R:PP:TTTT
Set braking time	SPT2:PP:TTTT	Xxxx:CPT2:PP:TTTT
Set smooth part	SPT2R:PP:TTTT	Xxxx:CPT2R:PP:TTTT
Set max. speed	SPVMAX:PP:VVVV	Xxxx:CPVMAX:PP:VVVV
Set final speed	SPVEND:PP:VVVV	Xxxx:CPVEND:PP:VVVV
Set rest path trigger	SPTTRG:PP:TTTT	Xxxx:CPTTRG:PP:TTTT
Set rest time trigger	SPXTRG:PP:XXXXXXXX	Xxxx:CPXTRG:PP:XXXXXXXX
Start positioning	SPSTART:PP	Xxxx:CPSTART:SS
Set time selector for ext. start	SPSELPOS:PP	Xxxx:CPSELPOS:SS
Set positioning type	SPMODE:PP:MMMM	Xxxx:CPMODE:PP:MMMM
Set actual position at existing value	SPSETX:XXXXXXXX	Xxxx:CPSETX:XXXXXXXX
Interrogate actual position	SPXIST?	Xxxx:CPXIST:XXXXXXXX
Interrogate nominal position	SPXSOLL?	Xxxx:CPXSOLL:XXXXXXXX

Fig. 11/4

11. List of the RS232 commands

11.6 Synchronization unit

The functionality of the synchronization unit cannot yet be controlled completely by RS232. If necessary, contact your dealer.

Command	Syntax	Reply
Reads status of synchronization unit aa: zpr_x_sel bb: zpr_n_sel cc: zpr_x_sel_ref dd: zpr_n_sel_ref	GETSYNC!	Xxxx:GETSYNC:aabbccdd
Sets status of synchronization unit	SETSYNC:aabbccdd	Xxxx:DONE

Fig. 11/5

11.7 Parking brake

Command	Syntax	Reply
Automatic brake on/off	SABR+ / SABR-	Xxxx:CABR+/CABR-
Switches the parking brake on (pull immediately, until next SBR-, no positioning possible)	SBR+	Xxxx:CBR+
Switches the parking brake off (release immediately, but automatic brake is active again after next positioning)	SBR-	Xxxx:CBR-

Fig. 11/6

11. List of the RS232 commands

11.8 Commissioning/Calibrating

These commands are used by the parametrizing software and made available to the user in an easy-to-use form. The user should trigger these commands only via the parametrizing software.

Command	Syntax	Reply
Load default parameter block (for motor EK87-120) Automatically carries out SAVE and RESET (Access only with controller enable switched off)	DSP!	Xxxx:CDP
Start motor identification	MOTID!	Xxxx:DONE
Decrement/increment offset analogue input 1	GND1-/GND1+	Xxxx:OK!
Decrement/increment offset analogue input 2	GND2-/GND2+	Xxxx:OK!

Fig. 11/7

11.9 Parameter commands

Before modifying individual parameters with these commands, you should contact your dealer. These commands permit direct uncontrolled access to almost all internal variables of the controller.

Command	Syntax	Reply
Read parameter	RIP:ooo	Xxxx:CIP:aaaa:HHHH
Read LONG parameter	RIPL:ooo	Xxxx:CIPL:aaaa:HHHHHHHH
Write parameter	SIP:ooo:HHHH	Xxxx:CIP:aaaa:HHHH?
Write LONG parameter	SIPL:ooo:HHHHHHHH	Xxxx:CIPL:aaaa:HHHHHHHH?
Write confirmation for commands SIP and SIPL	OK!	Xxxx:DONE

Fig. 11/8

11. List of the RS232 commands

11.10 Example of parametrizing

Set operating mode: position transducer and positioning control

Command	Syntax	Reply
Serial nominal speed value to 0	SN4:0000	xxxx:CN4:0000
Torque regulator off	SIN-	xxxx:CIN-
Positioning control on	SLA+	xxxx:CLA+
Switches synchronous mode on	SPO+	xxxx:CPO+
Position transducer on	SYNC+/SYNC-	xxxx:CSYNC+/CSYNC-
Nominal value integrator on/off	SHL-	xxxx:CHL-
Quit error	SQT+ SQT-	xxxx:CQT+ xxxx:CQT-
Controller enable on: Functions only when controller enable logic is set to Din5 and RS232	SRF- SRF+	xxxx:CRF- xxxx:CRF+

Fig. 11/9

11. List of the RS232 commands

Set position block 3 (this position block can be selected via the digital inputs as position 0):

Command	Syntax	Reply
Acceleration time 100ms	SPT1:03:0064	xxxx:CPT1:03:TTTT
30ms thereof smooth	SPT1R:03:001E	xxxx:CPT1R:03:TTTT
Braking time 200ms	SPT2:03:00C8	xxxx:CPT2:03:TTTT
200ms thereof smooth	SPT2R:03:00C8	xxxx:CPT2R:03:TTTT
Positioning type: relative related to last destination, current positioning is interrupted	SPMODE:03:0011	xxxx:CPMODE:03:MMMM
max. speed 1500 rpm	SPVMAX:03:05DC	xxxx:CPVMAX:03:05DC
Final stage speed 0 rpm	SPVEND:03:0000	xxxx:CPVEND:03:0000
Rest time trigger off	SPTTRG:03:0000	xxxx:CPTRG:03:0000
Rest path trigger off	SPXTRG:03:00000000	xxxx:CPXTRG:03:00000000
Positioning path 1.5 rev.	SPX:03:00018000	xxxx:CPX:03:00018000
Start positioning	SPSTART:03	xxxx:CPSTART:00
Positioning path -2.2 rev.	SPX:03:FFFDCCCD	xxxx:CPX:03:FFFDCCCD
Start positioning	SPSTART:03	xxxx:CPST

Fig. 11/10

11. List of the RS232 commands

Set current position to 1.5 rev.

Command	Syntax	Reply
Current position 1.5 rev.	SPSETX:00018000	xxxx:CPSETX:XXXXXXXX
Interrogate actual position	SPXIST?	xxxx:CPXIST:00018000
Interrogate nominal position	SPXSOLL?	xxxx:CPXSOLL:00018000

Fig. 11/11

Appendix A

A. Technical Appendix

A.1 Index

7-segment display 1-4, 5-4, 10-4

A

Acceleration time 9-27
Actual current value 5-11
Actual value display 4-21
Actual value window 2-7
Adapting the positioning module 5-16
Advanced 4-3
Aim of this manual IX
Amplification factor 5-12, 5-13, 5-14, 5-15
Analogue inputs 9-8
Analogue outputs 9-7
Automatic brake mode 9-15

B

Basic settings 4-3, 5-3
Basic values 4-16
Beginner 4-3

C

Calculating the braking time 8-30
Causes of faults 3-10
Command window 2-7, 8-4
Commands window 4-18

Commission	1-5
Communication parameters	3-6
Controller enable	5-3, 5-11, 9-15
Controller enable switch	1-4
Correction speed	5-18

D

Debugging purposes	9-20
Degree of effectiveness	7-3
Designated use	VIII
Destination	8-17
Destination positions	8-17, 8-19
Digital inputs	8-29
Digital outputs	8-20, 9-13
DOS shell	3-8

E

EEPROM	6-4
EMERGENCY STOP	VIII
Emergency stop	9-11
Entries	2-6
Error message	3-6
Error messages	9-17
Error window	3-9
Expert	4-3, 9-3

F

Fault	5-4
Fault acknowledgement	9-18

Fault in the data transmission	4-7
File	6-5
Final stage enable	5-11
First commissioning	4-19, 5-6
First program start	3-4
Flying saw	8-17
Flying saw	8-21
Further switching the positioning data records	8-39

G

Green LED	1-4
-----------------	-----

H

Higher-order controllers	8-37
--------------------------------	------

I

Icon bar	6-8, 9-32
Ignore	3-8
Incremental sensor	8-8, 8-25, 8-28
Incremental sensor output	8-21
Inductivity of the motor	7-5
Initial response	5-18
Installation program	3-3
Intermediate circuit	XII
Intermediate circuit voltage	9-14

L

Language of the parametrizing program	9-19
LED	9-13

Load conditions on the motor shaft	5-7
Low voltage network	VIII

M

Maximum current	6-7
Motor current	4-21
Motor identification	4-12
Motor speed message	9-12

N

Number of pole pairs	7-3
----------------------------	-----

O

Offline parametrization	3-8
Offset angle	7-3
Offset comparison	9-9
Overswing	5-18
Overswing	5-7

P

Parameter file	4-5
Parameter sets	4-12, 4-14
Parameters	7-4
Parameters of the speed controller	5-11
Parametrizing program	3-4
Parking brake	9-13, 9-15
Phase sequences	5-5
PI-controller	8-3
PI-controller	5-16

Pictograms	XIII
Position control	4-8
Position-synchronous mode	8-26
Positioning module	5-15
Positioning movement	5-15, 8-18
Positioning profile	8-15
Positioning profiles	8-14
Positioning range	4-17
Positioning start delay	9-16
Proportionality factor	8-22, 8-25, 8-26, 8-28

Q

Quick stop	8-32, 9-11
Quitted	1-5

R

RAM memory	6-4
Rated current	6-7
Ready messages	8-39
Rebound switch	8-16
Recording process	9-23
Reference position	8-9, 8-11
Reference travel	8-9, 8-11, 8-19
Regulator enable logic	4-11
Reset	6-4
Reversal mode	5-18
Reversing mode	9-26
Reversing path	9-27

S

Safety instructions	XII
---------------------------	-----

Search path	8-10
Serial interface	3-5, 3-7, 8-17, 9-3, 9-5, 9-20
Service	X
Setpoint jumps	9-9
Setpoint ramp	9-9
Setpoint-selectors	9-5
Signal curves	9-21
Speed current	4-21
Speed controller	5-15
Speed value	5-6
Speed-control mode	4-8, 8-6
Speed-synchronous mode	8-22
Status	8-37
Status bar	9-29, 10-4
Status list	10-3
Status window	2-7, 4-17
Switching further the positioning data records	8-37
Switching off stage enable	5-3
Synchronizing menu	8-24, 8-27

T

Target group	IX
Test movements	4-12, 4-14, 7-4
Test the controller enable	5-4
Text markings	XIII
Time constant	5-12, 5-13, 5-14, 8-26
Tolerance window	8-20
Torque constant	8-5
Torque-control mode	8-4
Torque-control mode	4-19

Trade marks	X
Trailing error	5-18
Transfer window	6-4, 9-3
Transferring modes	8-33

U

User instructions	XI
User modes	4-3

W

Warning	10-7
---------------	------

Conditions of use for Festo “electronic documentation”

I. Proprietary rights and scope of use

The file of your choice is subject to proprietary rights. Festo or third parties hold proprietary rights in respect of this electronic documentation. Insofar as the rights are granted to third parties, Festo has acquired the appropriate licences. Festo grants the purchaser the right of use under the following conditions:

1. Scope of use

- a) The user of the electronic documentation has the right to use this only for his own internal purposes on as many machines as desired within his business location (site). This right of use includes only the right to store the electronic documentation on the central processing units (machines) on the site in question.
- b) The electronic documentation may be printed to any desired extent at the user’s site, providing this copy is printed completely with the conditions of use and other user instructions.
- c) With the exception of the Festo logo, the user has the right to use illustrations and texts in the electronic documentation for creating his own machine and system documentation. The use of the Festo logo requires the written permission of Festo. The user himself is responsible for ensuring that both the illustrations and the texts used correspond with the machine/system or with the product.
- d) Further use is permitted within the following limits. Copying exclusively for use within the framework of machine and system documentation based on electronic documents of all the documented supplier components. Demonstrations to third parties exclusively with the assurance that no data material remains completely or partly in other net-

works or on another data medium or that it can be reproduced there.

The transfer of copies and printouts to third parties, except as defined in Section 3 below, as well as any other processing or use is not permitted.

2. Copyright notice

Every “electronic documentation” contains a copyright notice. This notice must be included in all copies and in all printouts.
© 1999, Festo AG & Co.,
D-73726 Esslingen

3. Transfer of licence

The user may transfer his/her licence to a third party subject to the scope of use and restrictions as defined in sections 1 and 2. The third party must be expressly made aware of these conditions.

II. Exporting the electronic documentation

If exporting the electronic documentation, the licensee is required to observe the export regulations of the Federal Republic of Germany and those of the country to which the electronic documentation is being sent.

III. Guarantee

1. Festo products are developed further as regards their hardware and software. The status of the hardware and software in the product can be seen on the type plate of the product. Festo does not guarantee that the electronic documentation corresponds to each hardware and software status of the product. The printed Festo documentation accompanying the product is decisive for the correspondence of the

hardware and software status of the product and the electronic documentation.

2. The information contained in this electronic documentation may be amended by Festo without prior notice and does not represent any commitment by Festo.

IV. Liability/Limitation of liability

1. Festo provides this electronic documentation in order to assist the user in creating his own machine and system documentation. Festo does not guarantee that the electronic documentation supplied corresponds to the product used by the user. The latter applies also to the use of extracts for the user’s own documentation.
2. Festo is also not liable for lack of economic success or for damages or claims from third parties, with the exception of claims arising from violation of the protective rights of third parties concerning the use of the electronic documentation.
3. The limitations of liability specified in paragraphs 1 and 2 do not apply in cases of malice aforethought or gross negligence where liability is compulsory. In such cases, Festo’s liability is limited to the damages recognizable to Festo based on the situation at hand.

V. Safety regulations/Documentation

The guarantee and liability claims specified above (sections III and IV) only apply if the user has observed the safety regulations in the documentation and the safety regulations regarding the use of the machine. The user is responsible for ensuring the compatibility of the electronic documentation with the machine he is using.